

12.1.24

ALL SALES FINAL

Competition  Products®

BROOM SHEET

20-80% OFF!

Racing Engine Parts



Call for our free 276 page full-line catalog!

TOLL-FREE: 1 (800) 233-0199

A

			WAS	NOW
Abrasives	CPXSTA76020	Grinding, Polishing Rolls, Deburr, 1/4" 80 Grit	2.29	1.75
Auto Reset Cir. Brkers	CPXFTX502-103	Fastronix Circuit Breaker 20 Amp	3.99	2.99
Auto Reset Cir. Brkers	CPXFTX502-101	Fastronix Circuit Breaker 10 Amp	3.99	2.99
Auto Reset Cir. Brkers	CPXFTX502-102	Fastronix Circuit Breaker 15 Amp	3.99	2.99
Adj. Vacuum Advance	CPXMOR72315	Moroso GM HEI, Adjustable	38.99	28.99
Air Pres Gauge	CPXMOR89560	Moroso 2 5/8 0-60 psi Pro Series	64.99	49.95
Alternator Bracket	CPXPWM882	Billet polished Alum. BBC, Short Water Pump	89.95	69.95
Alternator Kit	CPXPWM8-881	Powermaster 100 Amp Alt. Pulleys, Belt, Billet Alum. Drag SBC	349.99	319.95
Alternator Kit	CPXPWM8-880	Powermaster Pro 55 Amp racing, Billet Brks, Pulleys BBC	379.99	314.95
Alternator Kit	CPXPWM8-722	Powermaster Pro Series 100 Amp circle Track SBC	375.99	314.95
Alternator	CPXTFF7068ABULL	Tuff Stuff, Hi Output Ford 61-85, 100 Amp Chrome	171.99	143.95
Alternator	CPXTFF7068RD	Tuff Stuff, Hi Output Ford 61-85, 100 Amp Chrome	146.99	129.99
Air Fuel Ratio Kit	CPXDAY111004	3D Kit, Wego, Daytona Sensors	562.95	422.95
Alternator	CPXTFF7140ABULL	Tuff Stuff GM Chrome Silver Bullet 140 Amp 10 Si Case	269.95	199.95
Alternator	CPXTFF7140FBULL	Tuff Stuff GM Silver Bullet 140 Amp, 10 Si Case	185.99	169.95
Air Cleaner Stud	CPXPVT82196	6" Offset	2.99	1.99
Air Cleaner Spacer	CPXPVT82326	1 1/2" Spacer 5 1/8" Carb Necks	3.99	1.99

B

			WAS	NOW
Battery Box	CPXTAY48101	Taylor Alum NHRA ap. With 16' 2 ga Cable Kit	319.50	223.61
HP Book	CPXCARSA135	SA Design Engine Management, Advanced Tuning 128 pages	21.99	17.99
HP Book	CPXCARSA180	SA Design How to Supercharge, Turbocharge 144 pages	24.99	19.99
HP Book	CPXCARSA200	SA Design How to Rebuild Pontiac V-8 144 pages	26.99	22.99
HP Book	CPXCARSA252	SA Design Ford 351 Cleveland Max Tips 144 pages	25.99	21.95
HP Book	CPXCARSA394	SA Design Chrys Torqueflite A 904, A727 Rebuild 208 pages	27.99	23.99
HP Book	CPXCARSA55	SA Design Chev. S/B Parts Interchange Manual 144 pages	22.99	17.95
Battery Disconnect Switch	CPXLON45754	Longacre Panel, Weather Proof 2 Post	79.99	59.99
Battery Terminal Discon	CPXM0874103	Moroso top post with switch	27.99	19.99

BEARINGS (FORD)

			WAS	NOW
Main Bearings	CPXENGB307J-030	Enginotech Ford 351W .030	39.99	29.99
Rod Bearings	CPXENGBB214J-020	Enginotech Ford 289, 5.0L 302 .020	18.99	14.99
Rod Bearings	CPXENGBB608J-020	Enginotech Ford 351W .020	21.99	16.95
Main Bearings	CPXENGB3240J-020	Enginotech Ford 289/302/5.0L .020	21.99	16.99
Cam Bearings	CPXDURFP-33T	Durabond Ford 332-428 FE Coated, Race	96.99	74.95
Main Bearings	CPXBC306J	351W, STD, Open Box, Good Set, Engine Tech	27.99	14.95
Rod Bearings	CPXKEBCR813XPN010	Rod, .010 351C, M, 400 XP Series, King	65.99	49.95
Main Bearings	CPXACL5M590A-20	SB 289, 302, 5.0L Mains, ACL .020	35.99	19.99
Rod Bearings	CPXENGBB214J-0220	Enginotech Ford 289, 5.0L .302 .020	18.99	14.99

BEARINGS (SMALL BLOCK CHEVY)

			WAS	NOW
Main Bearings	CPXBA429H001	ACL Race Series, Large Radius, Small Journal SBCC Main Set, -.001	76.99	59.95
Main Bearings	CPX4926MA30	Sealed Power, SBC, .030, Main Bearing	99.99	59.95
Main Bearings	CPX4926MA30Si010	350 Chev., .010 Mains, King	40.99	23.95
Main Bearings	CPXCEPCB663HNC-1	SB L/J Rod, Tri-Armor Coated, Clevite, .001	145.99	115.99
Rod Bearings	CPXCEPCB1776P-40	SB Chev Clevite Rods w/ Housing Bore +.002, also LS1	24.95	14.95
Main Bearings	CPXCEPMS-1038HK	Clevite, SBC, 400 Mains, New But Opened, Tri Armor, Coated, Std	132.95	87.00
Cam Bearings	CPXDurchp-8R2	Cam Bearings, +.020 Oversize Kit, Dura Bond HP, SB Chev	49.99	39.99

BEARINGS (BIG BLOCK CHEVY)

			WAS	NOW
Main Bearings	CPXMS829HC-10	Clevite Triarmor Coated BBC .010	175.99	148.95
Main Bearings	CPXACL5M829A-030	ACL Mains, .030, Street Series, New But Opened	29.99	18.00
Main Bearings	CPXSEA7388MA	Chev Mains, STD., 8.1 Litre, Sealed Power	114.99	84.95
Rod Bearings	CPXSEA87200CH20	Rod, Speed Pro Comp Series, .020	96.99	76.99

C**HOWARDS CAMS &
RACING COMPONENTS****CAM SALE****SMALL BLOCK CHEVY**

			WAS	NOW
Hyd F/T	CPXHRCCL112981-06	390/410, 247/253, 106LC Oval T Lift Rule w/ Lifters	395.95	295.95
Hyd F/T	CPXHRCCL112431-08	449/449, 224/224, 108 w/ Lifters	329.95	249.95
Hyd F/T	CPXHRC112731-06	400/400, 245/251, .050, 106 LC, O. Track, Hi RPM, Lift Rule	239.95	189.95
Mech Roller	CPXHRC114563-08	4-7 Swap, 680/640, 273/279, 108, O Track	549.95	439.96
Mech Roller	CPX110713-06S	675/645, 259/267 106 Hi RPM, O Track	465.95	365.95
Mech Roller	CPXHRC110713-08	675/645, 259/267, 108, Hi RPM	459.95	367.96
Mech Roller	CPXHRC114033-06	4-7 Swap, 645/630, 2\73/283, 106, O Track	549.95	439.95
Mech Roller	CPXCCA12-564-4	SBC Comp Cams, Nitrous, Hyd F/T, 487/501L, 230/244, .050, 113 LC	268.95	214.40
Mech Roller	CPXCCA12-568-4	SBC Comp Cams, Nitrous, Hyd F/T, 507/525L, 240/253, .050, 113 LC	247.95	198.36

BIG BLOCK CHEVY

			WAS	NOW
Hyd F/T	CPXHRC120941-11	527/527, 225/225, .050, 111 LC, Gen IV	219.95	186.95
Hyd F/T	CPXHRC121861-10	612/595, 251/259, 110 LC, 3200-7400	219.95	169.95

LS CHEVY

			WAS	NOW
CPXHRC190275-17	H/Rol, 553/553, 216/224, .050, 117 LC		429.95	379.95
CPXHRC192865-13	H/Rol, 607/618, 227/243, .050, 113 LC		429.95	379.95
CPXHRC190805-15	H/Rol, 625/625, 236/250, .050, 115 LC		429.95	379.95
CPXHRC190305-15	H/Rol, 625/625, 242/242, .050, 115 LC		429.95	389.95
CPXHRC190255-13	H/Rol, 604/604 113/109, 113 LC		429.95	379.95

FORD

			WAS	NOW
Hyd F/T	CPXHRC219991A	SB, 480/480, 253/239, .050, 107 LC	213.95	148.95
Hyd F/T	CPXHRCCL222141-10	SB, 563/572, 230/234, 110 LC, Cam & Lifters	329.95	269.95
Hyd F/T	CPXHRCCL220891-08	SB, 592/601, 240/246, 108 LC, Cam & Lifters	329.95	269.95
Hyd F/T	CPXHRCMC220951-10DL	351W, 501/501/221/231, 110, Max Cert. Div. Lube Lifters	444.65	322.00
Mech F/T	CPXHRCCL221362-06	351W, 501/501, 244/252, 106 LC, Cam & Lifters	412.95	312.95
Hyd Roller	CPXHRC222735-10	351W, 581/581, 235/240, 110 LC	435.91	335.97
Hyd Roller	CPXHRCCL228085-09S	260-351W, 564/549, 243, 251, 109, Inc. Lifters, OE F/T Blks	829.95	674.95

CHRYSLER SMALL BLOCK

			WAS	NOW
Hyd Roller	CPXHRC770055-12	Magnum, 496/496, 209, 217, .050, 112 LC	519.95	448.54
Hyd F/T	CPXHRC710881-08	578/590, 248/254, .050, 108 LC	239.95	169.95

CHRYSLER BIG BLOCK

			WAS	NOW
Hyd F/T	CPXHRC722251-09	519/540, 243/251, .050, 109 LC	245.95	194.95
Hyd F/T	CPXHRC7520881-08	578/590, 248/254, .050, 108 LC	245.95	194.95
Mech F/T	CPXHE300JK3-0	3 Bolt, 435/435, 230/230, .050, 113 LC	249.00	129.00
Mech Roller	CPXHRC722113-12	600/600, 245/253, .050, 112 LC	489.95	418.95

OLDSMOBILE

			WAS	NOW
Hyd F/T	CPXHRC510011-12	448/475, 275/215, 112 LC, Street Force	238.95	174.95
Hyd F/T	CPXHRC517241-13	474/474, 232, 232, .050, 113 LC, AM Muscle	238.95	189.95
Hyd Roller	CPXHRCCL514155-10	549/549, 233/233, 110 LC, 4-7 Swap, w/ Lifters Inc.	1,129.95	974.95
Hyd Roller	CPXHRC518005-09	560/565, 227/235, 109 LC, 4-7 Swap	529.95	449.95

C

ELGIN CAMS CAM SALE

NEW CAMS ADDED EVERYWEEK - CALL AND ASK!

SMALL BLOCK CHEVY

		WAS	NOW
CPXELGE1005P	SBC Hyd F/T, 398/420, 194/204, .050, 112 LC, Low End Power	129.95	99.95
CPXELGE1069P	SBC Hyd F/T, 443/443, 214/214, .050, 110 LG, Low End Torque	149.95	119.95
CPXELGE1024P	SBC Hyd F/T, 510/510, 244, 244, .050, 108 LC, Pro Street. 3000 Stall	167.95	136.95
CPXELGE1006P	SBC Hyd F/T, 510/533, 244, 254, .050, 112 LC, Brke Racing	165.95	126.95
CPXELGE917P	SBC Mech F/T, 512/535, 262/273, 112 LC, Good w/ NOS, 4000 Stall	182.95	139.95
CPXELGE1025P	SBC Mech F/T, 579/579, 274/274, .050, 110 LC, Top End Power	175.95	129.95
ELGE-921-P	SBC HYD. F/T, L450/460, Lift, 224/224 @ .050, 114 LC	149.95	99.95
ELGE1101	SBC Hyd F/T, 398/420, 194/204, 104	121.95	99.95
ELGE1105	SBC Hyd F/T, 420/443, 204/214, 110	159.95	145.95
ELGE1129	SBC Hyd F/T, 420/429, 220/220, 110	121.95	109.95
ELGE1788	SBC Hyd F/T, 467/467, 222/222, 110	121.95	109.95
ELGE1166	SBC Hyd F/T, 453/480, 216/228, 112	121.95	109.95
ELGE1194	SBC Mech F/T, 547/566, 256/265, 105	210.95	162.95
ELGE1175	SBC Mech F/T, 538/556, 258/266, 106	149.95	138.95
ELGE1190	SBC Mech F/T, 518/518, 278/278, 112	162.95	99.99

BIG BLOCK CHEVY

		WAS	NOW
ELGE1170	BBC Hyd F/T, 540/540, 238/248, 114	162.95	138.95
ELGE1206	BBC Hyd F/T, 502/501, 218/225, 114	161.95	138.95

BIG BLOCK CHRYSLER

		WAS	NOW
ELGE1148	BB CHRY Hyd F/T, 521/551, 242/252, 109	179.95	149.95

FORD

		WAS	NOW
ELGE989P	Ford, 221/302, Hyd F/T, 497/520, 224/224, 112 LC, S/Strip	187.95	154.95
ELGE992P	Ford, 351W, Hyd F/T, 497/520, 224/234, 112 LC, S/Strip	172.95	144.95
ELGE91156P	Ford 351C, M, 400-Hyd F/T, 503/507, 224/233, .050, 108 LC, Low End Power	169.95	129.95
ELGE1049	Ford 351C M, 400 529/529, 218/218, 110	169.95	91.95

OLDMOBILE

		WAS	NOW
ELGE976P	Olds V8, 449/473, 204/214, .050, 112 LC, Low End Power	167.95	139.95

PONTIAC

		WAS	NOW
ELGE-1803-P	Elgin, 480/480 Lift, 229/228 @ .050, 112 LC	153.95	129.95

COMP CAMS

		WAS	NOW
CPXCCA11-742-9	BBC Mech. Roller, Comp Cams, 793/810 Lift, 285/312 @ .050, 116 LC	505.95	439.00
CPXCCA11-8225-9	BBC Mech. Roller, Comp Cams, 748/710, Lift, 274/282 @ .050, 110 LC	505.95	439.00
CPXCCA51-223-4	Comp Cams, Pontiac, Hyd F/T, 477/480, 224/230, .050, 110 LC	267.95	214.36

CRANKS

		WAS	NOW
CPXSACA440056	SCAT SBC, 4340, 400M, 3.75S, 6.0R	769.99	684.95
CPXSACA435011LW	SCAT SBC, F43, LW, 4340, 3.350S, 5.7R, 350M, light wt	1,025.99	914.95
CPXSACA435061LW	SCAT SBC, F43, LW, 4340, 3.75S, 6.0R, 2.0 Pin, light wt	1,079.95	929.95
CPXSACA44294500	SCAT BBC, Forged, 4.50S, 2 pc, 6.70R	1,006.99	899.95
CPXCLSE F&71V-MG	CALLIES Magnum Ford - SB, 4.100S, .2750J, 2.100R, Internal Balanced, 351C	3,683.00	2,996.00
CPXPVT350-443	SBC 350M, 4.0 S, 6.0 Up Rod, 4340, Bal. To 1529 B.W., 2pc	680.00	490.00
CPXBBB42B-MG	BBC CALLIES, 4.375 S, 6.535 R, 4340 Magnum, .010, 010, NEW	3,063.00	2,290.00
CPXEAG534740006100	Eagle LS, 4140 Forged, 4.0S, 58T, Int. Bal	769.99	669.99
CPXEAG435241706200	Eagle Ford, 351C M, 4.170S, 6.200 Up rod, 2.100J	859.99	759.99
CPXEAG445440026135	Eagle BBC, 454M, 4.0S, 1 Pc Rear	902.99	802.99

C

OVERSTOCK SALE

Quick Fuel Jets for Holley Carbs

Gas Reg. \$7.95 pr, now \$5.95 pr
 Alcohol - Reg \$9.50 pr, now \$7.95 pr
 Gas Jets QFT22-___ 50 - 110 available
 Alcohol Jets QFT22-___ 120 - 208 available



			WAS	NOW
Castor/Camber guage	CPXLON78260	Longacre, Super Accurate, caster/camber guage	189.99	164.95
Carburetor	CPXHLYO-80804	BKX Ultra XP, 850 CFM, DP, Black	1,138.95	1,053.00
CARB Service Assort	CPXQFT8-203	Dominator, 3-Circuit Kit, Quick-Fuel	22.73	59.99
Carb Kit 4150 D/P	CPXQFT3-305	Quick Fuel, Non-Stick, 850-1000 CFM	84.93	69.99
Connecting Rod Bolts	CPXARP1546402	Ford, ARP Wave Loc, 289, 302	79.99	624.95
Crankshaft Pulley	CPXMOR64201Moroso	Billet V-Belt, 1 Groove, BBC Short Pump	96.99	56.95
Crankcase Vacuum Pmp	CPXMOR22641	Racing, 4 Vane, Low Tension Rings	843.99	59.95
Carb Spacer	CPXJOM5016	Jomar Phenolic, 4150/4160, 850, 1", 4 Hole	62.99	24.95
Cable Bracket	CPXPRP1004	Billet Alum, 4150/4160, Morse Cable	82.49	499.00
Cam Degree System	CPXALT-DCAM-LSI	Altronics Digital Crank Socket Inserts	29.99	499.95
Carburetor	CPXEDE1410	Edelbrock Marine, 750 CFM, Elect Choke, Sq Flange	591.50	499.95
Carburetor	CPXEDE1413	Edelbrock Performer, 800 CFM, Elect Choke	561.95	499.95

D

			WAS	NOW
Duetsch Connector	CPXFTX401-969	Fastronix Prewired 12 Pin Connector	69.99	49.99
Duetsch Connector	CPXFTX401-958	Fastronix Prewired 8 Pin Connector	52.99	39.95
Dual Idler Gear Drive	CPXSAG784-12	SA Gear Pontiac V8	187.92	139.95
Dist. Ign Coils	CPXPRT30728	Petronix Coil on Plug Coils Ford Set 8 Flamethrower	242.95	169.95
Distributor	CPXPRTD131711	Pertronix Plug n Play, Billet Ford 351 W, VAC ADV	385.95	299.95
Distributor	CPXPRTD131811	Pertronix Plug n Play Billet Ford 351 W, MAC ADV	397.95	299.95
Distributor	CPXPRTD1350	Pertronix Flamethrower HEI, S/S, Ford SB	385.95	325.95
Distributor	CPXPRTD200811	Pert. Marine Billet, Plug n Play Chev V8, Ign Module	414.95	349.95
Distributor	CPXPRTD71200	Pert. Flamethrower HEI Multi Spark, Rev Lim. Pontiac V8	353.45	319.95
Distributor	CPXPRTD7130811	Pert. Flamethrower Billet Multi Spark, Rev Lim Ford SB	427.95	359.95
Distributor	CPXPRTD7100811	Pert. Flamethrower Billet, Multi Spark, Rev Lim Chev V8	414.45	349.95
Distributor Coil	CPXPRTD2010	Pert. Flamethrower Ignition Module, Ford TFI	77.45	59.95
Dist Race Kit	CPXPRT78070	Pert. Race only, HEI Complete Kit, Multi Spark, Rev Lim	206.45	154.95
Dist Race Kit	CPXPRTD8010	Pert. Complete Kit S/S HEI	175.45	139.95
Dist Race Kit	CPXPRTD78071	Pert. Comp. Kit Race HEI III Multi Spark Rev Lim	206.45	159.95
Degree Wheel Bolt	CPXJOM7051	SB Chev, Fits Most Wheels, Includes Bushing	4.99	2.99
Distributor	CPXPVT25-3935	Power Products, HEI Chev, Pro Black, SB/BB Chev	109.95	89.95
Distributor	CPXPFM67185	PROFORM, AMC HEI Racing, w/Vac Advance	236.93	199.00
Distributor	CPXPRTD1021	PerTronix, EI Flame Thrower S/S Chev	249.95	219.95
Distributor	CPXPRTD71370	PerTronix, HEI w/Mech. Advance, FORD 288-302, HEI Module w/ Multi Spark, Rev Limiter	449.50	389.50
Distributor	CPXPRTD1200	PerTronix, Flame Thrower, PONTIAC V-8, Vacuum Advance, HEI	269.95	239.95
Distributor	CPXPFM67040	CHRYSLER SB, HEI, With Vacuum Advance, Proform	232.99	214.95

E

			WAS	NOW
Electric Fan	CPXMARM093K	Maradyne, Low Profile 9" 5 Blade	133.05	99.75
Electric Fan	CPXMARM103K	Maradyne, Low Profile 10" 5 Blade	134.63	99.75
Electric Fan	CPXMARM122K	Maradyne, Low Profile 12" 5 Blade	169.08	129.95
Electric Fan	CPXPFM67012	Proform 12" 1200 CFM 2.75 Depth	39.95	29.95
Water Pump Elect.	CPXPFM66225B	+35 G.P.M. SB Chev. Blue	193.99	169.95
Elect. Ign. Conversion	CPXPRT1261	For Autolite Dist. No Points, Ford 49-74 6 Cyl	124.95	82.95
Exhaust Wrap	CPXDSN010102	Design eng. 2" x 50 ft. Tan	53.99	39.95
Exhaust Wrap	CPXDSN010117	Design eng. 1" x 100 ft, Tan	63.99	49.95
Electric Fan	CPXTSPHC8515	TSP Proflo w Shroud 16 3/4W, 18 3/4H, 1800 CFM	150.69	119.95
Electric Fan	CPXTSPHC6104	TSP Swept Blade 14" 900 CFM 3.130 Depth	39.95	29.95
Engine Warning Light	CPXLON40250	Longacre Fuel Pres. Adj. Kit Complete	53.99	43.99
Engine Programmer	CPX20093-1	Ram 2500 Truck, 6.7 Diesel, 6 Driving Modes, 2014-up	245.00	139.00
Electric Ignition Conv.	CPXPRT1361A	Chrysler 6 Cyl, 60-72 Pertronix Ignitor	139.95	89.95
Electric Fan	CPXPFM67014	Proform, 14", 1650 CFM	51.95	46.95

F

Fan-Electric	CPXMARM083K	Maradyne, Reversible S Blade - 8", Ford 351C, Complete Kit	111.49	79.00
Adapter Fitting	CPXMEZWP1000U	MEZIERE, 1" NPT Male to 1" NPT Female, Polished	26.59	22.00
Fitting	CPXAER15114	Coupler -8 AN to 8AN Straight	29.99	22.45
Fuel Gauge	CPXAUT5716	Autometer Phantom Electric	76.99	59.99
FuelBowl Quickchange	CPXHLY34-27	Sec. Bowl, Change w/o Bowl Removal	62.95	54.95
Fuel Pump	CPXHLY12-327-20	HOLLEY Mech., SBC, 170GPH, 8psi	189.95	162.15
Fuel Rails	CPXEDE3633	EDELBROCK, EFI Alum, -6 AN, BBC Kit, Pair	174.95	145.95
Fuel Level Guage	CPXAUT2643	Autometer Z series 2 1/16 universal	69.99	54.95
Water Pump Fittings	CPXMEZWP1125S	Meriere Inlet Fittings 1 1/4", Black	22.33	16.95
Water Pump Fittings	CPXMEZWP1000R	Meziere Inlet Fitting 2" Extended, Red	28.98	16.95
AN Wrenches	CPXPFM66972C	-6 AN Wrench	12.99	9.99
AN Wrenches	CPXPFM66975C	-12 AN Wrench	19.99	12.99
Flexplate CPX	CPXPMAPAX30214	PA Platinum, Extreme Series Ford 157T, 28 oz ex. SFI	145.00	99.00
Fuel Cell Cap & Bung	CPXPRP	Assembly w/ 6 Bolt Bung, Anodized	80.99	49.95
Fuel Rail Kit	CPXTSP81009SL	Billet Alum Rail, Braided Line, Fittings LS Series	118.00	88.95
Fuel Cell	CPXRJS3006201	RJS 8 Gal. 17 x 13 x 9 Std. Cap	109.95	96.95
Fuel Cell	CPXRJS3002601	RJS Drag 12 Gal 16 x 18 1/8 x 7 1/2	127.59	112.95
Fitting	CPXFRG224516	Hose End 45 Degree -16 AN Hose to Female -16 An	42.99	29.99
Fasteners	CPXARP644-1250	ARP 3/8 -16, 1.250 U.H.L 5pc	11.99	9.99
Fasteners	CPXARP 621-1500	1/44" x 20 1.500 U.H.L. 500 Shoulder .5 pk	16.95	12.95
Fasteners	CPXARP 621-0750	Stainless 1/4 -20, .750 U.H.L. Hex 5 pc	11.39	9.45
Fasteners	CPXARP 611-2000	Stainless 12 pt 1/4 -20, 2.0 U.H.L. 1.0, 5 pc	19.99	14.95
Fasteners	CPXARP 761-1002	Stainless Hex M8 x 1.25, 25mm U.H.L., 5 pc	19.99	14.95
Fuel Pump Speed Cont.	CPXAER16306	Billet Controller	484.95	299.95
4 Switch Panel	CPXFTX930-061	12v, 20A, 3 Color	45.95	28.95
Fuel Gauge Fitting	CPXMOR65310	Pressure 3/8 NPT Female to 3/8 NPT Male	20.99	12.95
Fuel Gauge Fitting	CPXMOR65315	Pressure 3/8 NPT Male to -6 AN Male	21.99	12.95
Fuel Press Reg	CPXAER13001	Injected Bypass Reg EFI Service Kit	39.95	19.95
Fitting 90 Degree	CPXRDH2090-10-1	Push Lock -10 AN Blue, Red Horse	24.27	12.95
Elbow	CPXRDH1000-12-1	Red horse Straight Swivel Ends -12 An	14.82	9.95
Hose Ends	CPXRDH4501-100S	Micron Redhorse 450I Cartridge	45.86	19.95
Fuel Filter	CPXRDH3100-06-06-2	Alum Line, Self Crimp -6 AN Male to 3/8 Line	17.95	9.95
Hard Tube Adapter	CPXRDH3100-06-06-1	Alum Line, Self Crimp -6AN Male to 3/8 Line	17.95	9.95
Hard Tube Adapter	CPXRDH818-08-2	Nut -8 AN 1/2" 2 pk	6.97	3.95
Hard Tube Nuts Sleeves	CPXRDH818-10-1	Nut -10 AN 5/8	6.04	2.99
Hard Tube Nuts	CPXRDH819-08-2	-8 AN 1/2 2 pk	6.97	3.99
Hard Tube Sleeve	CPXRDH816-10-06-1	-10 AN to 3/8 NPT	7.56	4.96
Male to Pipe Fittings	CPXRDH816-06-08-1	-6 AN to 1/2 NPT	3.76	2.76

SFI FLEXPATES CLP

CPXCLPPF-460 Ford 429-460 164T, Ext. Bal. 65.99
 CPXCLPPF-302E 164T, 28 oz, Ext. Bal. 65.95



G

MR GASKET PROMO



From 60%-80% off



			WAS	NOW
Mr. Gasket	CPXMRG5980	Collector Gaskets, Ultra-Seal, Steel Core, Laminate, 2.5" Diam., Pair	14.04	5.49
Mr. Gasket	CPXMRG7176C	Collector Gaskets, Copper-Seal, 3-Hole, 2.5" Inside Diam., Pair	18.36	7.99
Mr. Gasket	CPXMRG7420G	Collector Gasket, Soft Aluminum, 2.50" Dia., 3 bolt Holes w/ Bolts, Pair	16.11	5.95
Mr. Gasket	CPXMRG150B	Exhaust Gasket, Small Block Chev., Round Port, 1.50 Dia., Pair	14.04	7.47
Mr. Gasket	CPXMRG5902	Exhaust Gasket, Ultra-Seal Core Laminate, Rnd Prt, Chev Small Block, 1.63" Dia, Pr	21.61	7.95
Mr. Gasket	CPXMRG7402G	Exhaust Gaskets, Soft Alumi, Large Round Port, Chev Small Block, 1.63" Dia, Pr	26.47	10.95
Mr. Gasket	CPXMRG150	Exhaust Gasket, Hi Temp, Round Port, SB Chev, Pair (2 pr. 4.99 ea)	12.95	6.47
Mr. Gasket	CPXMRG3413	Header Collector Bolt Kit, 3/8-16, 1.0" Long, 3-Pieces	3.45	2.49
Mr. Gasket	CPXMRG9753	Wire Loom, 4-Dividers, Tall, Style Chrome, Pair	5.95	2.99
Mr. Gasket	CPXSCEP36156	Head Gasket, Ford SB, 4.155 Bore, .062 SCE Copper, 1 Pr., Pair	164.95	124.95
Mr. Gasket	CPXDGC3125HT	Head Gasket, SBC, ROL, 4.200b, .046, One pc	29.99	14.95
Mr. Gasket	CPXSCE5145243	Copper Head Gasket TITAN, BBC, 4.520b, .43 Pr	274.00	195.00
Mr. Gasket	CPXSCEP112050	Copper Head Gasket PRO SBC, 4.200B, .050 Pr	154.00	110.00
			WAS	NOW
Shift Lite tach	CPXAUT233904	Autometer 5" Black Face 10,000 rpm	213.99	169.95
Shift Lite tach	CPXAUT233905	Autometer 5" Black Face 8000 rpm	212.95	186.95
Autogauge Oil Press	CPXAUT2354	1 1/2", 0-100 psi Black Face Autometer	63.99	53.99
Gauge Mtn Cup	CPXAUT3203	Autometer 2 5/8 Chrome Mech	40.99	32.95
Warning Light	CPXAUT3241	Autometer Prolite Pressure Switch 18 psi	40.99	24.95
Warning Light	CPXAUT3240	Autometer Prolite Pressure Switch 30 psi	33.99	24.95
Water Temp	CPXAUT3332	Autometer Sport Comp Mech 2 1/16 100-250	104.99	94.95
Fuel Pres Gauge	CPXAUT4411	Autometer Ultralite Mech 2 5/8 0-15 psi	79.99	69.99
Water Temp	CPXAUT4431	Autometer Ultralite Mech Water Temp 140-260	121.99	103.99
Water Temp	CPXAUT5737	Autometer Phantom Elect 2 1/16 100-250	72.99	66.95
Vacuum Press Gauge	CPXCCGAUGE	Crankcase Vacuum Pressure Tester Gauge, CC Gauge	28.25	7.00
Fuel Press Gauge	CPXMRSMS01500	Fuel Pressure, 0-1500 PSI, Shock Proof, Nitrous	24.95	18.95
Oil Temp Gauge	CPXAUT3348	Oil Temperature, Autometer Sport Comp, 140-300 Degrees, Elect	98.99	76.95
Guide Plates	CPXPUT8032	SBC 5/16 raised set	28.99	22.95
Fuel Level	CPXAUT2643	Autometer Z series 2 1/16 universal	69.99	54.95

G

Dual Idler Gear Drive

CPXCLPTG-302 FORD SB, 260, 289, 302 Was 139.95 Now 69.95



H

Harmonic Bal.	CPXPBDBP1211N	Power Bond BBC 8.0" Int. Bal
Harmonic Bal.	CPXPBDBP1082N	Power Bond Ford 351 C, M, 6.50 Ext Bal
Harmonic Bal.	CPXATI917740	ATi Super Damp. BBC 7.074" Ext. Bal.
Harmonic Bal.	CPXATI917300	ATi Super Damp. BBC Alum Shell 7.074" Int Bal.

WAS	NOW
141.99	119.95
119.95	89.95
412.70	370.80
394.84	355.35



Brodix Heads can be returned for a full refund for any reason within 14 days, no exceptions. All sales final 14 days after date of invoice. Return shipping is the responsibility of the customer.



CYLINDER HEADS

FREE SHIPPING!

NEW BLEMS, 1pc each.
Need light work
Call for info.

40%-90% off

SMALL BLOCK CHEVY

			WAS	NOW
BRX11STDx	BRODIX	225cc 67cc 23 Deg	772.99	150.00
BRXWPBD1010	BRODIX	265cc 64cc 13.5 Deg CNC Ported	1239.95	750.00
BRXT-ISTDCNC	BRODIX	221cc 67cc 23 Deg	538.95	150.00
BRXBPAK285	BRODIX	285cc 52cc 13 Deg	785.95	250.00
BRXBPAK270	BRODIX	270cc 52cc 13 Deg CNC Ported	1448.00	500.00
BRXHHROCNC	BRODIX	225cc 67cc 23 Deg	538.00	100.00
BRXKC11XRO	BRODIX	225cc 67cc 23 Deg	1247.00	450.00
BRXBP11XRO233	BRODIX	225cc 67cc 23 Deg	690.00	250.00
BRXBPAK285	BRODIX	285cc 52cc 13 Deg	1247.00	500.00
BRXBPHH229	BRODIX	229cc 68cc 23 Deg	785.00	250.00
BRXBPHHR0225	BRODIX	225cc 67cc 23 Deg	755.00	200.00
BRXBPHHR0233	BRODIX	233cc 67cc 23 Deg	1247.00	500.00
BRXKC11SPX	BRODIX	225cc 67cc 23 Deg	529.00	150.00

BIG BLOCK CHEVY

			WAS	NOW
BRXPB5000	BRODIX	515cc 80cc 15 Deg	985.00	300.00
BRXBPPB1200CNC	BRODIX	483cc 72cc 12 Deg	985.00	300.00
BRXBRPB1204	BRODIX	515cc 71cc 12 Deg	1200.00	750.00
BRXBPPB1200	BRODIX	483cc 72cc 12 Deg	772.00	250.00
BRXKCBP1803	BRODIX	410cc 95cc 18 Deg	2026.00	750.00
BRXBRO2020002	BRODIX	13B-2extra 365 119 bare pair first	1880.00	1628.00

FORD

			WAS	NOW
BRXBF201	BRODIX	225cc 46cc 11 Deg	750.00	260.00
BRXST5.0	BRODIX	171cc 60cc 20 Deg	516.00	150.00

PROMAX CYLINDER HEADS

SMALL BLOCK CHEVY

		WAS	NOW
CPXPMX9225	PM Shocker, Full CNC Ported SBC, 225cc/64cc Straight Plug Assembled Hyd. Roller to .600, Pr	1844.00	1659.00
CPXPMX9228A	PM Shocker Full CNC Ported 225cc, 64cc Angle Plus Assembled. Mech Roller To .700 Tit.Ret. PR.	2237.00	2013.00

BIG BLOCK CHEVY

		WAS	NOW
CPXPMX9370	Pro Max Shocker, CNC Ported BBC 370 cc/121cc PR. Bare	2653.00	2387.00
CPXPMX9372	Pro Max Shocker, CNC Ported BBC 370 cc/121cc Assm. Mech roller to .700 2.350/1.880 V.	3256.00	2830.00
CPXPMX9201	Pro Maxx Series BBC 200cc, 64cc Straight Plug Bare, Pr	950.00	855.00
CPXBR02020002	Brodix BB-2XTRA 365, 119, Bare PR	1880.00	1599.00

H

PROMAX CYLINDER HEADS

FORD

			WAS	NOW
CPXPMX92104	Pro Max Ford 289-351W CNC Ported 210cc, 64cc Hyd. Roller. 2.08/1.6v to .600 Lift PR		2024.00	1821.00
CPXPMX9176	Pro Max Ford SB 289-351W 60cc, 175cc, Pr		979.00	881.00
CPXPMX9172	Pro Maxx Series Ford FE 72cc, 170cc Assm. PR Hyd. Roller		1964.00	1767.00

EDELBROCK HEAD | SBC

			WAS	NOW
CPXEDE60989	Edelbrock E-Tec SBC 64cc, 200cc, 2.02/1.6 valves 1.460 OD Springs Hyd F/T, Assembled, Each		891.50	691.50

WORLD HEAD | SBC

			WAS	NOW
CPXWRD043610	World S/R SBC 170, 67cc, Str. Plug Bare PR.		1304.00	1152.00
CPX5303-1B	World Windsr Jr., 180cc, 58cc, 1.94/1.6, Bare, Small Crack in Valve Cover Area, 1 pc		490.54	250.00

			WAS	NOW
Head Gasket	CPXSCEP110662	SCE Pro Copper Solid 4.060B, .062 Each	85.30	69.58
Head Gasket	CPXSCEP112050	Copper, SBC 4.200 Bore, SCE, .043 PR	279.95	199.95

			WAS	NOW
Header Studs	CPXSPE2595T	12 Pt. 3/8 x 1.700 w/ Nuts	64.95	57.95

			WAS	NOW
Heat Tape	CPXDSN010395	1.5" x 30 ft to 850 Degrees	52.99	41.95
Heat Tape	CPXDSN010396	2" x 15 ft. to 850 Degrees	35.99	29.95
Heat Tape	CPXDSN010394	1.5" x 15 ft. to 850 Degrees	29.99	24.99

			WAS	NOW
Helmet	CPXGFR13004XLGBK	G Force Revo Full Face SA-2020 X-Large Black	319.00	274.95

			WAS	NOW
Harness	CPXGFR6001BK	G Force 6 pt. Pro Dual Sub Straps	119.00	89.95

			WAS	NOW
Hose Ends	CPXFRG100006	Fragola Banjo, 9/16 - 18 to -6 AM, Swivel Seal	66.99	44.99

			WAS	NOW
Ignition Box	CPXPRT512	Pertronix Digital HP Big Power Multiple Spark	294.45	249.95

INTAKES

			WAS	NOW
CPXWEI8022WND	Weiland	Weiland Stealth Dual Plane Chrys SB	409.95	368.95
CPXWEI7531WND	Weiland	Weiland Team G SBC 2" Raised Plenum	355.95	284.76
CPXTSP 84000	TSP	Dual Plane, Ford 260-302, polished 1500-6500	287.59	249.95
CPXEDE7525	Edelbrock	Edelbrock RPM Air Gap SBC Dual quad	484.95	430.00
CPXEDE2896	Edelbrock	Edelbrock Super Victor II BBC 565 S/D 9.800 D	762.95	595.00
CPXEDE2913	Edelbrock	Edelbrock Super Victor SBC vortec	473.95	395.00
CPXBROBM2017-0	Brodix	Brodix BBC, Single Plane, Dominator, Oval port	932.99	732.99

INTAKE FASTENERS

			WAS	NOW
CPXSPE2930	Specialty	Chrys BB Hex Grade 8	8.99	5.99
CPXSPE2932	Specialty	Chrys BB 12 pt Grade 8	9.99	7.99
CPXSPE2927	Specialty	Chrys SB 12 pt Grade 8	14.99	11.99
CPXSPE2935	Specialty	Ford 429-460 Hex Grade 8	19.99	12.99
CPXSPE2937	Specialty	Ford 429-460 12 pt. Grade 8	24.17	17.95
CPXSPE2915	Specialty	Ford FE 390-428 Hex Grade 8	19.99	12.99
CPXSPE2917	Specialty	Ford FE 390-428 12 pt Grade 8	25.99	19.99

INTAKE FASTENERS

			WAS	NOW
CPXSPE2917	Specialty	Ford FE 390-428 12 pt Grade 8	25.99	19.99
CPXSPE2910X	Specialty	Ford 351C Hex Grade 8	13.99	10.99
CPXSPE2910	Specialty	Ford 289-351W Hex Grade 8	9.99	7.99
CPXARP 155-2105	ARP	Ford 429-460 12 pt Chrome Moly	40.99	34.95
Intake Manifold Bolts	CPX4652	Zinc 6 Pt., SBC, + Chrysler Kit, Hex Head	14.95	7.99
Intake Manifold Bolts	CPXARP430-2101	ARP Stainless Steel, CHEV S/B, 12 Pt.	56.99	48.95
Infared Thermometer	CPXMRW89720	Non-Contact, 0-960 Degrees	65.99	58.00

J

			WAS	NOW
Carb. Jet Kit	CPXQFT22	Pairs, .050, .051, .053, .057, .180, .184, .185	64.00	29.95

L

			WAS	NOW
Leak Down Tester	CPXLON73010	Longacre, Dial Type, inc. Hose, 14mm Spark Plug ad.	153.99	129.99

LED INDICATORS

			WAS	NOW
LED Indicators	CPXFTX304-005	Chrome, 3" Wire Leads, 7/16 Hole 12v Red	8.95	6.95
LED Indicators	CPXFTX304-006	Chrome, 3" Wire Leads, Amber 12v	8.59	6.95
LED Indicators	CPXFTX304-007	Chrome 3" Wire Leads Green 12v	8.95	6.95

LIFTERS

			WAS	NOW
CPXPVT8099-1	Big Block Chevy	Roller, BB Chev, Mech. Roller, +.300 Tall, 7 Pair, +.002 Body, Ea., PR	450.00	250.00
CPX91167D	Big Block Chevy	Roller, BBC, Hyd. Street Series, to 6500 RPM, Dyno Run 1/2 off!	579.95	289.00
CPXELGHL-4003S	Big Block Chevy	Roller, BBC, Retro Hyd. Roller, ELGIN Tie Bar, Set	779.94	539.99
CPXCCA899-16	Big Block Chevy	Comp Cams Endure -X Mech Rollers BBC Offset Int. Seats	742.95	624.77
CPX911065	Small Block Chevy	Roller, SBC Hyd. Roller, Howards Max Effort, Stock Blocks Only, Set	559.95	499.95
CPXSRP2116LS-1	LS Chevy	Roller, LS Chev, Retro Tie Bar, Pairs for 7 Cyls		30.00
CPXQLC36-817-16	Chevy V8	Hyd F/T, Chev V-8, Performance Lifters, Set (while they last)	89.95	65.99
CPX91718B	Chrysler	Mech F/T, Chrys, 383-400, 392-426, Hemi, Dtrect Lube, EDM, Blem. Set	289.95	249.95
CPX91715B	Chrysler	Mech F/T, Chrys, SB, BB, Hemi, Appearance Blem, Set	289.95	229.95
CPXSRP3316BBR	BB Chrysler	Roller, B/B Chrysler, Mech. Roller, Retro Tie Bar, Set		350.00
CPXCCA829-16	BB Chrysler	Roller, B/B Chrysler, comp Cams, Mech. Roller, Endurex, Set	628.95	574.95
CPXISKSO382-H	Ford	Isky Ford V 8 289-460 Mech F/T .024 EDM Hole	359.99	289.99
CPX91212B	Ford	Hyd. F/T, Ford, 221-351W, Max Effort, Appearance Blem., Set	219.95	174.95
CPXSRP4214VDL-1	Ford	Hyd F/T, Ford SB, 429, 460, Variable Duration, 14 Pieces		5.00

LUBE

			WAS	NOW
CPXMSALUBE	Rod Bolt & Engine Assy. Lube, 25 oz., Aerospace Quality, 50 Pack, .79		149.50	39.50
CPXMSALUBE	Rod Bolt & Engine Assy. Lube, 25 oz., Aerospace Quality Each		2.98	0.99

M

			WAS	NOW
Main Caps	CPXMIL11160	Milodon Chev 350 Fact. 4 Bolt Block 3pc	349.95	274.95
Main Cap Strap	CPXH350RSDS	Howards Dry Sump, Chev SB 350, (Fits Rear Caps)	31.95	11.00
Main Stud Kit	CPXARP235-5701	ARP BBC IV 4 Bolt w/ Windage T	171.99	149.95
Mini Spool	CPXMGPMS9-28	Motive Gear Ford 8" & 9" 28 Spline	28.95	22.95
Mini Spool	CPXMGPMS88-31	Motive Gear Ford 8.8" 31 Spline	80.95	68.95
Mini Spool	CPXMGPMS88-28	Motive Gear Ford 8.8" 28 Spline	80.95	68.95
Mini Spool	CPXMGPMS9-8	Motive Gear Ford 8" & 9" 28 Spline	28.95	22.95
Mini Spool	CPXMGPMS75-28	Motive Gear GM 7.5" 10 Bolt 28 Spline	80.95	68.95
Mini Spool	CPXRIC78-7526-1	Richmond 26 Spline, 10 Bolt, 7.5 GM Richmond	89.99	69.99

M

Motor Plates	CPXTWP2004	TWRCP Mid Mount Plates, Ford 351M, 400, 426-460, 30"W Steel, .090	92.95	72.95
Motor & Trans Mt. Sets	CPXENE4-1124G	Ford Mustang 5.0L 84-95 Complete	290.31	229.95

N

NITROUS SYSTEMS & ACCESSORIES

			WAS	NOW
CPXIND19746-BL	Nitrous Purge Systems	Induction Systems Kit 6AN	135.00	108.00
CPXPRP1103	Nitrous Solenoid & throttle Brkt.	4150 Carb w/ Ford Cable	134.99	89.99
CPXAUT3328	Nitrous Pressure Gauge	Autometer Sport Comp, 0-2000 psi, Mech	129.99	99.97

O

OIL PANS

			WAS	NOW
CPXMOR20190	Moroso Kicked Out Sump SBC 7 qt. 8 1/4" D		247.99	199.95
CPXMIL30755	Milodon Stock Replacement Chrys 360 Baffled		258.95	164.95
CPXMIL30570	Milodon 4x4 Offroad Ford 429-460 8qt		479.95	379.95
CPXMIL30920	Milodon Ford 420-460 Low Profile 8 qt 9 1/2 D		453.95	369.95
CPXMIL30955	Milodon BBC Gen 5/6 Low Profile 7 qt 8 1/2 D		514.95	395.00
CPXMIL31125	Milodon Ford SB 302 7 qt 8 1/4 D Rear Sump		458.95	295.95
CPXMOR21308	Moroso Sportsman Series SBC 7 qt 8.0 Deep		251.99	224.95
CPXMOR20160	Moroso Deep Sump SBC 7 qt 9 1/2 D SBC		252.99	197.95
CPXCOPCP100KORB	Champ Circle Track SBC 8 qt 7" D w Kickout		475.50	409.95
CPXCOPCP55RB	Champ SBC Circle Track 8 qt 8" D		197.70	169.95
CPXCOPCP57RB	Champ SBC IMCA 8 qt 7" D		197.70	159.95
CPXCOPCP60RB	Champ T Style Low Profile 8 qt 8" D		184.80	164.95
CPXMOR21019R	Moroso Eliminate Drag SBC Dart/Rocket 7 qt 8.25 D		641.99	499.95
CPXMOR20193	Moroso SBC Dart/Rocket 7 qt 8 1/4 D		484.99	384.99
CPXCOPCP55RB	Champ SBC Circle Track 8 qt 8" D		197.70	169.95
CPXMIL30925	Ford SB, 8 Qt., 289/302 S/S, Front Sump Chassis, S/Strip		379.95	329.95

OIL PAN PICKUPS 1/2 OFF

			WAS	NOW
CPXMOR24170	SBC for Std vol Pump 8 1/4" Deep, 1/2 off		61.99	31.00
CPXMOR24150	SBC for Std vol pump 9 1/2" Depth, 1/2 off		59.99	29.95
CPXMEL12566	SBG Bolt on w 7.5" Pan Oval, 1/2 off		47.73	37.73
CPXMIL18301	BBC 8 1/2 D Pan, 1/2 off		74.95	37.50
CPXMIL18396	Ford 429/460 8 qt 9 1/2" D Press, 1/2 off		80.95	40.50
CPXMIL18398	Ford 429/460 8 qt 9 1/2" D Bolt on, 1/2 off		60.95	30.50
CPXMIL18451	Ford 10 3/4 D Pan Big Block 429-460, 1/2 off		103.95	52.00

OIL PUMPS

			WAS	NOW
CPXMOR22162	Moroso Blue Printed BBC Hi Vol Race		322.99	224.95
CPXMEL10227	Select Melling Ford 4.6,5.4L 2 & 4 Valve, StD Vol. Hi Press.		506.34	399.95
CPXMEL10555	Melling Perf. SBC Hi Vol, 3/8 Inlet		142.99	99.95
CPXMEL10070-900SS	Melling Hi Vol H Pres BB Chev 9" Deep Pan		561.31	390.00

OIL PUMP TOOLS & ACCESSORIES

			WAS	NOW
CPXMSD8513	Oil Pump Drive	Chev SB/BB	249.95	209.95
CPXMOR22300	Oil Filter	Moroso Chrome Chev & Others	31.99	24.95
CPXKEV1004-3/4	Pick Up Tube	SBC 8" Pan 7 3/4 Deep 3/4" Dia	49.99	29.99
CPXSPE2626F	Oil Pan Stud Kit	Competition BBC 8740 Mat.	52.99	39.95
CPXPVT10-6649	Oil Filter Cutter	Inspect For Particles, For Potential Problems	29.99	22.95
CPXMIL18445	Oil Pump Pickup	Milodon, Ford FE, 10" Pan Depth	112.95	94.95
CPXMOR62210	Oil Pump Primer	Moroso, Ford, SB FE 390-428 1/4" Hex Drive	26.48	18.95

P SUPER PISTON DEALS

PISTONS | BBC

		WAS	NOW
CPXSRP212141	4.125B, 3.76S, 6.135R, KB Hyper, Dome 5/64	795.99	686.00
CPXUEMKB361-STD	4.125B, 4.0S, 6.135R, KB Hyper, Dome 5/64	639.99	479.00
CPXUEMKB397-STD	KB Hyper, 4.250B,4.25S, 6.235R, 10-1, 1/16R	519.36	389.52
CPXSEAH426CP-S	Speed PRO Hyper, 4.25B, 4.0S, 6.135R, 8.5, 5/64	319.95	274.95
CPXUEMI448HC.040	Silvolite Hyper, 4.290B, 4.0S, 6.135R 2VR, 8.2 CR 5/64	290.00	217.50
CPXUEMKB203-40	KB Hyper, 4.290B, 4.0S, 6.135R, 9-1, 5/64 R	532.64	399.48
CPXUEMKB397-40	KB Hyper, 4.290B, 4.25S, 6.535R, 10-1, 1/16 R	519.36	389.52
CPXWISPTS514A6	Wiseco Protru 4.310B, 4.0S, 6.135R, 9.4, 1/16 R	648.52	549.00
CPXUEMIC9950-60	Icon FHR Forged 4.310B, 3.76S, 6.135R, 8.5, 5/64	835.12	626.34
CPXUEMIC9920-60	Icon FHR Forged, 4.310B, 4.0S, 6.135R, 8.2, 5/64	777.92	583.44
CPXUEMKB397-60	KB Hyper, 4.310B, 4.25 S, 6.535R, 10.1, 1/16	519.36	389.52
CPXUEMIC603-70	4.320B, 4.250S, 6.385R, Dome Forged, 1/16	909.99	699.00
CPXUEMIC997-34	Icon 2618, 4.50B, 4.250S, 6.385R, 13-1, 1/16	1,053.84	794.88
CPXARI1130381	Arias 2618, BBC, 12.5 CR, 6.358, 4.0S, 4.500b 1/16	749.91	374.00
CPXCP338SL-509	4.500B, 4.0S, 6.385R, 2618, 13-1, .043, 1/16, 3/16, Arias	890.00	494.00
CPX170667	Big Duke/Chief, 4.530B, 4.250S, 6.535R, .043, 1/16, 18 Degree Ported, CH1.120, 14.3 CR	1,021.95	675.00
ROS99827	18 degree Dome Ross 2618, 4.60B, 4.25/4.75S, 6.535/6.70R Nitrous	975.00	819.95

PISTONS | SBC

		WAS	NOW
CPXUEM3452HC.040	Hyper 3.776B, 3.48S, 5.7R, 9-1, 58cc, 4VR, 5/64R	219.60	169.95
CPXWISPTS526A3	Wiseco ProTru Forged, 3.766B, 3.48S, 5.7R, 8.9 CR. W Rings, 1/16R	599.56	549.95
CPXWISPTS508A3	Wiseco ProTru Forged, 4.00 B, 3.48S, 5.7R, 8.8 CR w Rings, 1/16R	605.39	549.00
CPXUEMIC9965-30	Icon FHR, 4.030B, 3.75S, 6.0R, 9.6 CR, 1/16R	706.88	530.11
CPXUEM9910HC-40	KB Hyper Claimer, 4.040B, 3.75S, 5.7R, 12.5 CR, 5/64R	396.64	297.48
CPXUEMIC718-40	ICON Forged, 4.040B, 3.75S, 6.0R, F/T, 2618, 2VR, 1/16	829.99	630.00
CPXUEMIC604-40	ICON Forged, 4.040B, 3.48S, 6.0 R, F/T, 2618, 1.5mm	743.95	575.00
CPXWISPTS509A6	Wiseco ProTru Forged, 4.060B, 3.48S, 6.0R, 8.8 CR W Rings, 1/16R	605.39	549.00
CPXUEMKB231-60	KB Hyper, 4.060 B, 3.48S, 5.7R, 10.3 CR, 1/16R	519.04	389.00
CPXSEAH617CP60	Spleed Pro Hyper, 4.060B, 3.48S, 5.7R, Dome, 5/64	302.00	279.00
CPXUEMKB168-30	KB Hyper 4.155B, 3.75S, 5.7R, 9.8 CR, 5/64R	538.72	389.00
CPXUEMKB128-30	KB/Hyper, 4.155B, 3.750S, 5.6.0R, F/T, 2 VR, 1/16	509.99	429.00
CPXWISPTS535A4	Wiseco ProTru Forged, 4.165B, 3.75S, 6.0R W Rings, 1/16R	605.39	549.00
CPXUEMKB168-40	KB Hyper, 4.165B 3.75S, 5.7R, 9.8 CR, 5/64R	538.72	389.00
CPXUEMIC757-60	Icon 2618 Forged, 4.185B, 3.75S, 6.0R, 9.4 CR, 1/16R	881.60	619.95
CPXUEM9907HC-60	KB Hyper, 4.185B, 3.48/3.75S, 5.7/5.565R, 5/64R	342.00	256.00

PISTONS & RINGS | BBC

		WAS	NOW
CPXMAH930225405	Mahle LSX, Chev 4.005, 3.622, 6.125, Forged, 9.8 CR with File Fit	835.95	699.95
CPXMAH930211455	Mhale Power Pak SBC, 4.155, 4.0, 6.0, 10.6 CR, with File Fit Rings	912.64	799.95
CPXMAH930211465	Mahle Power Pak SBC, 4.165, 4.0, 6.0, 10.6 CR, with File Fit Rings	912.64	799.95

PISTONS | CHRYSLER

		WAS	NOW
CPXWISK472X25	Hemi 4.080 Bore, 3.580S, 6.243R, 8.7CR, Turbo, 1.5, 3.0MM, 2618, Wiseco, w/ Rings	859.00	527.00

P

PISTONS | FORD

		WAS	NOW
CPXUEMIC9925-STD	Icon FHR Forged 351W, 4.0b, 3.5S, 5.956R, 9.8, 5/64	503.99	399.00
CPXSEAH273CPS	Speed Pro\Hyper, 302, 4.0b, 3.0S, 5.090R, 8.6 CR, STD	179.59	146.95
CPXUEMKB151-STD	4.0 B, 3.5S, 5.956R, F/T, 2 VR, Hypereutectic, 5/64	381.99	347.00
CPXUEMIC736-30	Icon 2618 Forged 302 4.030b, 3.0S, 5.090R, 10.6, 1/16	908.64	631.48
CPXUEMIC736-30	Icon 2618 Forged 351W, 4.030b, 3.850S, 5.956R, 13.3-1, 1/16	908.64	631.48
CPXUEMIC721-30	SB, 4.030B, 4.0S, 6.200R, F/T 2 VR, 2618, 1.5MM	822.99	669.00
CPXMAH930247130	Piston & Rings, MAHLE, 4.030B, 3.400S, 5.40 R, Dome, 1.0MM	912.64	795.00
CPXWISPTS512A4	Wiseco ProTru Street Forged, 4.0406b, 3.255S, 5.40, 10.1, 1/16	599.56	519.95
CPXUEM3191HC.040	Ford 460, 3.85S, 6.60R, 8.6, 4.040B, Hyper	268.72	224.95
CPXUEMIC739-40	Icon 2618 Forged, 4.040B, 3.40S, 5.40R, 11.8, 927 Pin, 1/16	908.72	681.48
CPXUEMIC9925-60	Icon FHR Forged 351W, 4.060B, 3.5S, 5.956R, 9.8, 5/64	687.20	499.00
CPXUEMIC9971-60	Icon FHR Forged 347, 4.060Bm 3.40S, 5.40R, 9.5, 5/64	715.68	536.76
CPXUEM3191HC.060	Silvolite Hyper 460, 4.060B, 3.85S, 6.605R, 8.6	268.72	201.50
CPXUEMKB137-STD	KB Hyper 460, 4.390b, 3.850S, 6.605R, 11-1, 5/64	577.04	432.78
CPXWISPTS530A3	Wiseco ProTru Street Forged 460, 4.390b, 3.850S, 6.605R, 1/16, w/Rings 11.5	642.29	499.90
CPXUEMKB137-30	KB Hyper 460, 4.390b, 3.850S, 6.605R, 11-1, 5/64	577.04	432.78
CPXUEMKB137-60	KB Hyper 460, 4.420b, 3.850S, 6.605R, 11-1, 5/64	577.04	432.78
CPXUEMKB13240	KB Hyper, 4.400B, 3.850S, 6.605R, F/T, 5/64	552.99	456.80

PISTONS | PONTIAC

		WAS	NOW
CPXUEMIC941-30	2618 Forged, 10.4 F/T, 4.250S, 6.8R Icon, 1/16R	859.99	599.99



PISTONS SALE

- Forged from 2618-T61 Billet Aluminum Bar Stock
- Less than 1% Silicon Particulate Content
- Oversized Valve Pockets
- Accumulator Grooves for improved ring seal
- CNC turned skirts
- Radius Valve Reliefs
- Forced pin oilers
- Aircraft quality wrist pins included
- Machined Oil Drain Back Holes
- Lock Removal Indents
- Double Spirolox

PISTONS | HOWARDS PROMAX 2618 PISTONS W/ PINS

		WAS	NOW
CPH839011304	LS Chev F/T, 4.005B, 4.0S, 6.125R, 11.5/66cc	809.95	619.95
CPH839530304	LS Chev F/T, 3.905B, 3.622S, 6.125R, 10.1/66cc	809.95	619.95
CPH840342608	SB Chev Dome, 4.030B, 3.75S, 5.7R, 13-1/64cc	859.95	679.95
CPH840442128	SBC Inv. Dome, 4.040B, 3.75S, 5.7R, 8.8/64cc	809.95	699.95
CPH840442405	SBC F/T, 4VR, 4.040B, 3.75S, 5.7R, 11-1/64cc	809.95	616.95
CPH840455205	SBC F/T, 4.040B, 3.48/3.5S, 5.7R, 10.4/64cc	809.95	616.95
CPH840456405	SBC 4VR F/T, 4.040B, 3.48/3.5S, 5.7R, 10.6/64cc	809.95	616.95
CPH840642128	SB Chev Inv. Dome, 4.060B, 3.75S, 5.7R, 8.8/64cc	809.95	699.95
CPH840642405	SB Chev 4VR F/T, 4.060B, 3.75S, 5.7R, 11-1/64cc	809.95	616.95
CPH840656405	SB Chev 4VR F/T, 4.060B, 3.75S, 5.7R, 10.7/64cc	809.95	616.95
CPH841506206	SB Chev F/T, 4.155B, 3.875S, 6.0, 11.8/64cc	809.95	628.95
CPH841600306	SB Chev F/T, 4.165B, 3.75S, 6.125R, 11.5/64cc	809.95	628.95
CPH841606503	SB Chev Dome, 4.165B, 3.875S, 6.0R, 13.2/64cc	859.95	679.95
CPH841612206	SB Chev F/T, 4.165B, 3.48/3.5S, 6.125R, 10.8/64cc	809.95	628.95
CPH841612608	SB Chev Dome, 4.165B, 3.48/3.5S, 6.125R, 12.9/64cc	859.95	699.95

P

PISTONS | HOWARDS PROMAX 2618 PISTONS W/ PINS

		WAS	NOW
CPH841612608	SB Chev Dome, 4.165B, 3.48/3.5S, 6.125R, 12.9/64cc	859.95	699.95
CPH841642306	SB Chev F/T, 4.165B, 3.75S, 5.7R, 11.5/64cc	809.95	628.95
CPH849325205	SB Chev F/T, 4.035B, 3.48/3.5.S, 5.7R, 10.4/64cc	809.95	616.95
CPH853127111	BBC Inv. Dome, 4.310B, 4.25S, 6.385R, 8.2/119cc	899.95	704.95
CPH853127303	BBC F/T, 4.310B, 4.25S, 6.385R, 8.7/119cc	899.95	704.95
CPH853139643	BBC Dome, 4.310B, 4.0S, 6.385R, 12.1/119cc	899.95	713.95
CPH855021638	BBC Dome, 4.50B, 4.375S, 6.385R, 13.4/119cc	899.95	713.95
CPH855024638	BBC Dome, 4.50B, 4.0S, 6.535R, 12.3/119cc	899.95	713.95
CPH855027123	BBC Inv. Dome, 4.50B, 4.250S, 6.385R, 8.2/119cc	899.95	704.95
CPH855027303	BBC F/T, 4.50B, 4.25S, 6.385R, 9.3/119cc	899.95	704.95
CPH856021610	BBC Small Dome, 4.60B, 4.375S, 6.385R, 10.9/119cc	899.95	704.95
CPH860316305	Ford SB 302 F/Tf, 4.030B, 3.25S, 5.40R, 9.7/64cc	799.95	619.95
CPH86410305	Ford SB 302 F/T, 4.040B, 3.40S, 5.40R, 10.6/60cc	799.95	542.95
CPH860416305	Ford SB 302 F/T, 4.040B, 3.25S, 5.40R, 9.8/64cc	799.95	619.95
CPH860423601	Ford SB 351W Dome, 4.040B, 4.0S, 6.25R, 13.4/60cc	843.95	662.95

MANLEY PUSHRODS 1/2 OFF

		WAS	NOW
CPXMAN25344-8	3/8, 8.250, Tapered Moly, .135 Wall, 8 Pcs, 1/2 off	147.56	73.78
CPXMAN25775-16	5/16, 7.625, Moly, .080 Wall, 16 Pcs, 1/2 off	156.09	78.04
CPXMAN25873-8	3/8, 7.250, Moly, .080 Wall, 8 Pcs, 1/2 off	107.41	53.70
CPXMAN25344-1	3/8, 6.250, Moly, .135 Wall, Ea, 1/2 off	18.45	9.22
CPXMAN25710-16	5/16, 8.550, Ford 429-460, STD L, Moly, .080 Wall, 16 Pcs, 1/2 off	156.09	78.00
CPXMAN25744-16	5/16, 8.150, Ford 351W, STD L, Moly, .080 Wall, 16 Pcs, 1/2 off	156.09	78.00
CPXMAN25796-8	3/8, 9.250, BBC, STD, Ex. Moly, .080 Wall, 8 Pcs, 1/2 off	107.41	53.70
CPXMAN25755-16	5/16, 7.550, Moly, .080 Wall, 1/2 off	156.09	78.04
CPXMAN25701-16	5/16, 8.250, Moly, .080, 1/2 off	156.09	78.04

PUSHRODS

		WAS	NOW
CPXMRP516-9500BC	Manton, 5/16, 9.500" Seam, Chr.. Moly, .080, 8 Pcs	168.00	68.00
CPXHRC95122-8	3/8, Moly, Howards, 11.450", .080, 8 Pcs	89.00	46.25
CPXHRC95499-8	3/8, Moly, Howards, 9.900", .080, 8 Pcs	87.95	52.95
CPXELGPR-780	Elgin, .065 Wall, Heat Treated, 5/16, 7.850, 16 pcs	85.00	55.00
CPXELGPR-782	Elgin, .065 Wall, Ht Treated, 5/16, 7.950, 16 Pcs	85.00	55.00
CPXELGPR-783	Elgin, .065 Wall, Ht Treated, 5/16, 8.0", 16 Pcs	85.00	55.00
CPXELGPR-15620	Elgin, .110 Wall, Moly, H Treated, 210 Tip, 8 Pcs, 6.200, 5/16	71.92	49.95
CPXELGPR-15615	Elgin, .110 Wall, Moly, H Treated, 210 Tip, 8 Pcs, 6.150, 5/16	71.92	49.95
CPXELGPR-13805	Elgin .137 wall, H/T Moly, 210 Tip 8.050" 3/8	158.95	124.95
CPXELGPR-13820	Elgin, .137 Wall, H/T, Moly, 210 Tip, 16 Pcs, 8.200, 3/8	159.95	124.95
CPXELGPR-13865	Elgin, .137 Wall, H/T, Moly, 210 Tip, 4 Pcs, 8.650, 3/8	39.95	23.95
CPXELGPR-13910	Elgin, .137 Wall, H/T, Moly, 210 Tip, 4 Pcs, 9.100, 3/8	39.95	23.95
CPXELG1400	SBC STD, L, Elgin, .065 Wall, H/T, Moly, to 7000 RPM	80.00	59.99
CPXELG1410	SBC, +.100, Elgin, .065 Wall, H/T, Moly, to 700 RPM	80.00	59.99

		WAS	NOW
Power Valve & Power Valve Cap	CPXWEGWCW-125-16.5	13.97	9.89
Power Valve & Power Valve Cap	CPXWEGWCW-1001	13.99	9.99
Polishing Cartridge Rolls	CPXSTA726020	2.29	1.75
	Wegner, Blueprinted, Hi-Flow, 16.5 hg		
	Oval Track, Use with Nitrophyl Floats		
	Port & Polish 1/4 x 1 1/8, 80 grit		

R

			WAS	NOW
Radiator	CPXNTH205070	Northern Alum. Muscle Car, 26-1/4 x 8-1/2 x 3-1/8	359.95	299.95
Radiator Hose Filler	CPXMOR63745	Moroso, 1.25" to 1.25", Hose I.D.	44.95	29.95
Remote Battery Jumper	CPXPVT28-4138	Between Rounds Charging	12.95	8.95

RETAINERS

			WAS	NOW
CPXPAC-R334	PAC Steel 7°, 11/32, 1.240-1.265 Dia Springs		88.00	68.00
CPXPAC-R348-16	PAC Steel Mini 8 Degree, 1.374 O.D. Moly		88.00	67.00
CPXCCA772-16	Comp Cams, Titanium, GM, Gen III, 7°		325.95	225.95
CPXCCA732-16	Comp Cams, Titanium, 10°, 1.50-1.550 Dual		387.95	310.36
CPXCCA733-16	Comp Cams, Titanium, 10°, 1.625 Dual		387.95	310.36
CPXCCA785-16	Comp Cams, Titanium, 10°, 1.585 OD, .725 ID		387.95	299.00
CPXVT03809	VTO 10° Chrome Moly, 1.500-1.550 +.100		63.84	48.00
CPXMAN23630-16	10° Titanium, Manley, 1.437-1.550 Springs		299.95	199.95

RINGS

			WAS	NOW
CPXSEAR9346-35	Speed Pro 4.155B, Plasma Molly 1/16, 1/16, 3/16, File Fit, .005, Low T		163.99	139.95
CPXR934005	Speed Pro 4.0B+5B, Plasma Moly, 5/64, 3/16		154.95	125.00
CPXR940105	Speed Pro 4.0B+5B, Plasma Moly, 1/16, 3/16		139.95	69.95
CPXSEAR9343-5	Speed Pro 4.0B+5B, Plasma Moly, 1/16, 3/16		151.99	124.95
CPXR977110	Speed Pro 4.010B, Plasma Moly, 1/16, 3/16, File Fit		104.99	82.95
CPXSEAR9771-25	Speed Pro 4.020+5B, Plasma Moly, 1/16, 3/16		129.99	99.99
CPXSEAR9343-35	Speed Pro 4.030+5B, Plasma Moly, 5/64, 3/16		154.95	129.00
CPXSEAR9343-65	Speed Pro 4.065B +5 B, Plasma Molly, 5/64, 5/64, 3/16		159.99	129.95
GPXE180K30	Speed Pro 4.080B, Plasma Moly, 5/64, 3/32, 3/16, Moly		89.95	59.00
CPXSEAR9346-5	Speed Pro 4.125+5B, Plasma Moly, 1/16, 3/16		158.95	124.95
CPXSEAR10248-25	Speed Pro 4.145+5B, Plasma Moly, 1/16, 3/16		147.99	124.99
CPXE-299X30	Speed Pro 4.150B, Cast, 5/64, 5/64, 3/16, S. Power		62.95	26.95
CPXSEAR9346-45	Speed Pro 4.165+5B, Plasma Moly, 1/16, 3/16		158.99	124.95
CPXSEAR9905-5	Speed Pro 4.250B, Plasma Moly, 5/64, 5/64, 3/16		132.99	114.95
CPXSEAR9903-5	Speed Pro 4.400B, Plasma Moly, 5/64, 3/16		139.99	109.99
CPXR201135	Speed Pro 4.500+5B, 043 043 3.0mm P.Moly		149.50	78.95
CPXR1059560	Speed Pro 4.560B, 1/16, 3/16, Plasma Moly		147.99	69.95
CPXSEAR10595-60	Speed Pro 4.560B, 1/16, 3/16, Plasma Moly		73.00	99.00
CPXCA4125H40	Grant H40, 4.165 B, 5/64, 5/64, 3/16, Claimer Proven		112.95	98.95
CPXRP4125B65	Grant 4.185+5 B, Race Proven, 1/16, 1/16, 1/8		147.89	49.95
CPXHAS2M5538025	Hastings 4.025B, Moly 1/16, 1/16, 3.0mm, File F		127.99	69.99
CPXJEPJ10008-4030-5	JE Rings 4.030B+5, Pro Seal, Plasma M 1/16, 3/16		190.87	139.95
CPXJEPS100S8-4155-5	JE Rings 4.155B+5, Sportsman, 1/16, 3/16		139.79	99.95
CPXJEPS100S8-4155-5	JE Rings 4155B, Sportsman ProSeal, 1/16, 3/16		133.13	94.95
CPXJEPJ10008-4155-5	JE Rings 4.155B, Race Series, 1/16, 3/16		213.72	164.95
CPXJEPJ100F8-4155-5	JE Rings 4.155+5B, ProSeal, Plasma M, 1/16, 3/16		233.95	174.95
CPXMAH3947MS-15	Mahle 3.927 Bore, 1.5, 1.5. 3.0mm, Drop in Plasma Moly, 1/2 Off		152.99	74.33
CPXJEPJ100F8-4165-5	JE Rings 4.165+5 Pro Seal 1/16, 3/16		224.41	174.95
CPXJEPS100S8-4280-5	JE Rings 4.280+5 Sportsman 1/16, 3/16		139.95	99.95
CPXJEPJ100F8-4350-5	JE Rings 4.350+5 Premium 1/16, 3/16		242.95	179.95
CPXJEPJ1008-4500-5	JE Rings 4.500+5 Premium 1/16, 3/16		260.95	188.95
CPXJEPJ100F8-4530-5	JE Rings 4.53+5 Pro Seal 1/16, 3/16		282.95	199.95
CPXMAH4005MS-112	Mahle 4.0 +5B, Plasma Moly, 1.0, 1.0, 2.0mm		180.98	90.50
CPXMAH4025MS-15	Mahle 4.020 +5B, Plasma Moly, 1.5, 1.5, 3.0mm STDT		156.50	99.95
CPXMAH3947MS-15	Mahle 4.947 Bore, 1.5, 1.5, 3.0mm, Drop In Plasma Moly, 1/2 Off		152.99	74.33
CPXMAH4605ML	Mahle 4.600 B, Plasma Moly Low Tension, 1/16, 3/16		127.24	73.95
CPXTOTT3690-5	Total Seal 4.0B, TSI, Gapless, STD Tension, 1/16, 3/16		330.51	278.95
CPXTOTCT36905	Total Seal 4.0B, TNT, Extreme, Nitrous, Supc, Turbo, 1/16, 3/6, STD. T.		237.95	181.95
CPXTOTT3690-25	Total Seal 4.020B, TSI, Gapless, 1/16, 3/16		330.51	269.95
CPXTOTS9090-30	Total Seal 4.030B, TSS, Street, 5/64, 5/64, 3/16		218.31	174.95
CPXTOTTS3690-45	Total Seal 4.040B, AP, Gapless, STDT, 1/16, 3/16		427.55	364.95
CPXENGR43258-30	Enginotech 4.350B Chrys 5/64 3/16 cast		52.99	42.99

R

RINGS

		WAS	NOW
CPXENG43258-30	Enginotech 4.350B Chrys 5/64 3/16 cast	52.99	42.99
CPXTOTMS3690-35	Total Seal 4.030+5B, AP Gapless, 1/16, 3/16	418.04	325.00
CPXCUSTOM-CR-08	Total Seal 4.040+5, .031, 1/16, 3/16, RACE	287.30	149.95
CPXTOTMO390-45	Total Seal 4.045B, Gapless Maxseal, 1/16, 1/8	292.20	234.95
CPXTOTCRH201055	Total Seal 4.050+5B, Classic Race, 15, 1.5, 3.0MM, 1/2 Off	118.59	59.29
CPXTOTS9090-60	Total Seal 4.060B, TSS Gapless, 5/64, 3/16	201.37	173.00
CPXTOTT3690-65	Total Seal 4.060+5B, TSI Gapless, 1/16, 3/16	299.17	254.00
CPXTOTCT3690-65	Total Seal 4.060B, TNT, Extreme, AOP, STDT, 1/16, 3/16	231.78	189.99
CPXTOTCR0690-5	Total Seal 4.125B, Classic, Race, Moly, STDT, 1/16, 3/16	147.13	124.95
CPXTOTCR0190-35	Total Seal 4.155B, Classic, Race, Moly, STDT, 5/64, 3/16	164.95	129.95
CPXTOTMS0690-35	Total Seal 4.155B AP, Gapless, Steel, STDT	453.25	379.95
CPXTOTCR0690-45	Total Seal 4.165B, Classic, Plasma, Moly, Race, STDT, 1/16, 3/16	148.98	124.91
CPXTOTMS0690-45	Total Seal 4.165B, AP, Gapless Top, Steel, STDT, 1/16, 3/16	451.21	351.95
CPXTOTMS4301-64	Total Seal 4.185B, AP, Gapless Top, Steel, STDT, .043, 1/16, 3/16	453.21	375.95
CPXTOTT9190-35	Total Seal 4.280B, TSI, Gapless, 1/16, 3/16, STDT, 1/16, 3/16	330.51	289.95
CPXTOTCR2090-35	Total Seal 4.280B, Classic, Plasma, Moly, Race, 5/64, 3/16, STDT	173.00	139.99
CPXTOTCR2090-65	Total Seal 4.310B, Classic, Plasma, Moly, Race, 5/64, 3/16, STDT	173.00	139.99
CPXTOTM9190-195	Total Seal 4.440B, Maxseal, Gapless Top, STDT, 1/16, 3/16	332.15	279.99
CPXTOTM9190-255	Total Seal 4.470B, Maxseal, Gapless Top, STDT, 1/16, 3/16	332.15	279.99
CPXTOTT9130-5	Total Seal 4.560B, TSI, Gapless, STDT, 1/16, 3/16	363.61	324.99
CPXTOTTS4309-5	Total Seal 4.600B, AP, Steel, Gapless, STDT, .043, 1/16, 3/16	427.56	369.95
CPXSEAR10248-5	Total Seal 4.125+5B, Plasma Moly, 1/16, 3/16	151.99	119.95
CPXTOTM1003-5	Total Seal 4.130B, Maxseal, 1/16, 1/8	300.64	266.00
CPXTOTML0690-5	Total Seal 4.130B, Maxseal Gapless, 1/16, 3/16	300.64	255.00
CPXTOTT0690-25	Total Seal 4.145+5B, TSI Gapless, 1/16, 3/16	299.17	259.95
CPXTOTCR0690-30	Total Seal 4.155B, Classic Race, 1/16, 3/16	133.75	99.95
CPXTOTM1003-35	Total Seal 4.155+5B, Maxseal File Fit, 1/16, 1/8	300.64	255.00
CPXTOTCL0190-40	Total Seal 4.165B, Claimer Gapless, 5/64, 3/16	151.24	134.95
CPXTOTCL0690-40	Total Seal 4.165B, Claimer Gapless, 1/16, 3/16	173.43	154.95
CPXTOTM1003-45	Total Seal 4.170B, Maxseal Gapless, 1/16, 1/8	300.64	259.95
CPXTOTCR0190-65	Total Seal 4.185B, Classic Race, 5/64, 3/16	149.25	119.95
CPXTOTS2090-30	Total Seal 4.280B, TSS Street Series, 5/64, 3/16	233.50	199.95
CPXTOTCT9190-195	Total Seal 4.440+5B, TNT Extreme, 1/16, 3/16	271.46	239.95
CPXTOTM9190-285	Total Seal 4.530+5, Maxseal Gapless, 1/16, 3/16	306.95	259.95
CPXTOTCS2016	Total Seal 4.560+B, Classic Steel, Race, 1.5, 1.5, 3.0MM, New but Opened	325.00	270.00
CPXTOTML5010-30	Total Seal 4.630B, Maxseal Gapless, 043, 043, 3/16	358.89	309.00
RFS RING DEBURRING	RFS Ring Deburring Stones for eng gap, course + fine. 1/2 off	7.50	3.75

RING & PINION

		WAS	NOW
CPXRICGM75390	Excel Richmond GM, 7.5", 3.90, Fits 3.23 & Up, Case	218.99	175.99
CPXRICGM75342TK	Excel Richmond GM, 7.5", 3.42, Fits 3.08 & Down, Case	218.99	175.99
CPXRICGM73355TK	Excel Richmond GM, 7.5", 3.55, Fits 3.08 & Down, Case	238.99	191.99
CPXRICGM82411	Excel Richmond GM, 8.2", 10 Bolt, 65-72, 4.11	238.99	191.99
CPXRICGM85342	Excel Richmond GM, 8.5", 10 Bolt, 3.42	264.99	211.99
CPXRICGM85373	Excel Richmond GM, 8.5", 10 Bolt, 3.73	234.99	187.99
CPXRIC12BC342	Excel Richmond GM, 8.875" Car, 12 bolt, 3.42, 3 Series Case	239.99	191.99
CPXRIC12BC355	Excel Richmond GM, 8.875" Car, 12 Bolt, 3.55, 3 Series Case	239.99	191.99
CPXRIC12BC456	Excel Richmond Gm, 8.875" Car, 12 Bolt, 4.56, 4 Series Case	239.99	191.99
CPXRIC12BT342	Excel Richmond GM, 8.875" Car, 12 Bolt, 3.42, 3 Series Case	240.99	192.70
CPXRIC12BT410T	Excel Richmond GM, 8.875" Truck, 12 Bolt, 4.10, 3.08-3.42 Case	240.99	192.70
CPXRICF9486	Excel Richmond Ford, 8.8", 4.86	252.99	202.99
CPXRICF9514	Excel Richmond Ford, 9", 5.14	252.99	202.99
CPXRICF9486	Excel Richmond Ford, 9", 4.86	252.99	202.99
CPXRICF9514	Excel Richmond Ford, 9.0", 5.14	252.99	202.99
CPXMGGPF890389	Motive Gear, Ford 9"	364.99	264.99
CPXMGGP888390	Motive Gear, GM 12 Bolt, 3.90	454.99	389.00
CPXMGGP888411	Motive Gear, G.M.. 8.875, 12-Blt., 4.11	319.99	219.99
CPXMGGP888390	Motive Gear, Ford, 8.8, 3.90	454.99	354.99

R

RING & PINION

			WAS	NOW
CPXMGPF890389	Motive Gear, Ford, 9", 3.89		364.99	264.99
CPXMGPF890457	Motive Gear, Ford, 9", 4.57		359.99	259.99
CPXMGPF890486	Motive Gear, Ford, 9", 4.86		384.99	284.99
CPXMGPG885373	Motive Gear, GM, 8.5, 10-Blt, 3.73		371.99	185.00
CPXRIC49-0034-1	Richmond GM, 8.5, 10 Bolt, 3.90		409.99	327.99
CPXRIC49-0039-1	Richmond GM, 8.875 Car, 12 Bolt, 3.73, 307-373, Case		364.99	291.99
CPXRIC69-0031-1	Richmond GM, 8.87 Car, 12 Bolt, 4.10, 390 Up Case		339.95	271.96
CPXRIC69-0304-1	Richmond GM, 8.87 Car, 12 Bolt, 4.10, 307-373, Case		469.99	375.99
CPXRIC69-0053-1	Richmond Dana 60, 4.56		419.95	335.96
CPXRIC69-0179-1	Richmond Ford, 9", 4.11		389.95	311.96
CPXRIC79-080-1	Richmond Ford, 9", Pro, Drag, 4:57, 35 Spline		719.99	575.99
CPXRIC69-0169-1	Richmond GM, 8.5, 10 Bolt, 4:88		414.99	331.99
CPXRIC69-0169	Richmond, GM 10 Bolt, 4.58		414.99	299.00

			WAS	NOW
Ring & Pinion Install Kit	CPXRIC83-1019-1	GM 12 Bolt, C Axle, 30 Spline, 4.10	126.99	99.95
Ring Deburring Stones	STONES RFS	End Gap 1/2 off	7.50	3.75

Rockers	CPXPFM66910	Alum Roller Proform SBC, 3/8, 1.5R, Self-Align	224.99	149.95
Rockers	CPXSCP1002	Scorpion Race Rollers, SBC, 3/8, 1.6R	402.38	338.00
Rockers	CPX6279R	SB Ford, Steel Long Slots, 7/16 Stud, Roller Tip, 1.7R w/ Balls,	129.95	29.95
Rockers		Nuts, Blems. (Light Rust)		

Rocker Switch Panel	CPXFTX930-013	Fastronix, Triple, Red	31.99	24.95
Rocker Switch Panel	CPXFTX930-023	Fastronix, Triple, Amber	31.99	24.95
Rocker Switch Panel	CPXFTX930-024	Fastronix, Quad, Amber	37.99	29.95
Rocker Switch Panel	CPXFTX930-025	Amber	21.99	18.95

Rod Cap Screws	CPXMSAMSP05005	Aerospace, Pro Series, 245000 PSI, 5/16" x 1.450" (Set of 16), 70% off	138.00	41.40
Rod Cap Screws	CPXARP4P1.600-LU	7/16, 1.60" U.H.L., 8740 ARP, Ea	6.99	4.99
Rod Lube	CPXMASLUBE	Aerospace, Rod Bolt Assembly Lube, 25 oz. (50 pack - .79 cents each)	2.93	0.99

ROD ENDS

			WAS	NOW
CPXQAICML5	C-Series Carbon-Steel, 5/16-24-Male, .313 bore		4.99	2.99
CPXQAICFL6	C-Series Carbon-Steel, 3/8-24-LM-Female, .375 Bore		3.99	2.99
CPXQAICFR7	C-Series Carbon-Steel, 7/16-20-Female, .438 Bore		5.59	3.99
CPXQAICMR7	C-Series Carbon-Steel, 7/16-20-Male, .438 Bore		6.99	4.65
CPXQAICMR8	C-Series Carbon-Steel, 1/2-20-Male, .500 Bore		6.99	5.25
CPXQAICFR10	C-Series Carbon-Steel, 5/8-18-Female, .625 Bore		11.99	7.85
CPXQAICML10	C-Series Carbon-Steel, 5/8-18 L.H. Male, .625 Bore		10.99	6.99
CPXQAIXMR6	X-Series-Chromoly, 3/8-24, Male, .375 Bore		14.99	11.99
CPXQAIXMR8	X-Series-Chromoly, 1/2-20, Male, .500 Bore		18.99	14.99
CPXQAIXML8	X-Series-Chromoly, 1/2-20 L.H. Male, .500 Bore		15.99	13.95

\$1,000 off

Ultimate X
X-Beam Billet Rods

GM DURAMAX 6.6L
EXTREME DUTY X-BEAM FORGED BILLET RODS

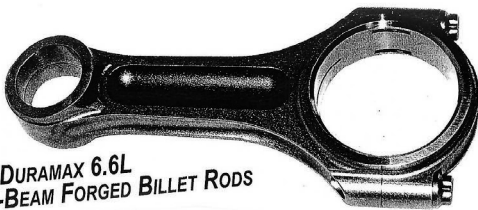

Billet Rods - Duramax

2000+ H.P., GM Duramax 6.6 LX Beam Billet Rods. Ultimate Strength and Weight. EDM Lasered Hole From Rod Bearing Journal To Wrist Pin. 7/16" ARP 2000 Capscrews, Extreme Duty Turbo or Supercharger Applications. No Better Duramax Rod Made. Set.

5 sets left	WAS	NOW
CPXBX6420	2,999.00	1,999.00

R

RODS

		WAS	NOW
CPXOLIC6125STSW-8	Oliver SBC 6.125, 2.100J Speedway	1,599.97	1,399.00
CPXOLIC6535BB-8	Oliver BBC 6.535	1,615.90	1,466.00
CPXWISBC6385-990	Wiseco Boost Line, BBC, 6.385, 2.200, .990 Pin	1,680.35	1,295.00
CPXWISLS6125-927	Wiseco Boost Line, BBC, 6.125, 2.100, .927 Pin	1,680.35	1,295.00
CPXEAGCRS5400C3D	Eagle Ford SB, 5.400, H Beam, Bushed .927 Pin, 2.100 J	514.99	411.99
CPXEAGFS15700B	Eagle SBC F51 ARP 7/16 CS, 4340, 5.7 bushed	409.99	325.50
CPXEAGSIR5400CB	Eagle I Beam, 5140, 5.400" Bushed, .927 Pin, 2100J	321.99	257.50
CPXEAGSIR5840BBLW	Eagle I Beam, 5.850" Bushed, ARP, Caps, SBC	319.99	287.99
CPXEAGSIR5956FP	Eagle I Beam, Ford 351W, 5.955, Press P, 3/8 ARP	312.99	281.60
CPXEAGSIR6135P	Eagle I Beam, BBC, 6.135, Press Pin, 7/16 ARP	389.99	350.00
CPXSCA65400927A	Scat, H Beam, Ford, SB, 5.400, Bushed, ARP 2000, .927 Pin'	625.95	539.95
CPXSCA66625	Scat, H Beam, 4340, Pontiac, 6.625, ARP, Float Pin	671.99	624.95
CPXCBC-5933-i	SB Ford, 5.933, Billet I-Beam, ARP 2000, 7/16 2000 Caps	699.99	474.00
CPXSPM1-274-019	SBC 6.0", H-Beam, Speedmaster, 4340, 7/16 Caps	545.00	445.00
CPXSCA6540092720	Ford SB, 5.400, H-Beam, Scat, ARP 7/16 Caps	709.00	450.00
CPXPPF6000	Howards, SBC 6.0" ARP 2000 Cps, 650 HP, Fractured Cps, 585 gm, Slight Narrow Beam	516.95	395.95
CPXBX5945SRT	Howards 5.945, Billet, X-Beam, 7/6 ARP 2000, 22mmp, Firsts, 1/2 Off, Dodge Neon SRT	873.99	436.84
CPXPR59001771	Howards 5.900, Billet, 7/16 ARP 2000, 22mmp, Firsts, 1/2 Off, Mitsubishi 4G63	873.69	436.84
CPXBR6001RB30WM	Howards 6.001, Billet, 7/16 ARP 2000, 31mm Pin, 6 Cyl., Balanced, 1/2 Off, NIS RB30	995.00	499.50
CPXBR6001RB30	Howards 6.001, Billet, 7/16 ARP 2000, 21mm Pin, 6 Cyl., Firsts, 1/2 Off, Nissan RB30	995.00	524.95

CPXHRCTS61252100	Howards Tracksmart SBC L/J, 6.125 4340 H beam, 7/16 ARP2000 caps	679.95	479.95
	\$200.00 off! 479.95.		

ROTATING ASSEMBLY

		WAS	NOW
Rotating Assembly	CPXEAGB15402L04068 SBC Eagle 350, 4.040B, 3.48S, One Pc. Rear, Cast Crank, Cast Pistons, F/T 9.8 CR/64, SIR I Beam Rods, Moly Rings, King Bearings, Flexplate, Balanced	1,249.95	799.95
Rotating Assembly	CPXEAG111534500 Eagle BB Chev., 572 1pc Seal, 4.500B, 4.500S, 10.200 Deck, 4340 Forged Crank, SRP 2618 Pistons, 14.2, 118 CC, 6.700" 4340 H. Beam Rods, ARP Caps, Plasma Moly Rings, King Pro Series Bearings	2,299.00	1,999.00
Rotating Assembly	CPXEAGB15455L04068 SBC, 383, Cast, 3.75 Crank, 5.7 Sir Rod, Hyper F/T, 1.05, 1 Pc. Seal, 4.040 Bore, Flexplate, Moly Rings, King Bearings, Bal.	1,115.99	1,015.99

RPM MODULE KIT

		WAS	NOW
RPM Module Kit	CPXMSD87451 MSD, 5,100-5,900	49.95	37.95

S

SAFETY

		WAS	NOW
CPXRJS2004400106	Safety Jacket, RJS Elite Single Layer, X-Large Black	98.99	87.95
CPXRJS200400105	Safety Jacket, RJS Elite Single Layer, Large, Black	98.99	87.95
CPXSQ355002	Safety Gloves, Race Quip Double Layer Gloves SFi Small Black	59.95	39.95
CPXSQ30300080	Safety Shoes, Race Quip, Mid Top Size 8	89.95	74.95
CPXSQ121015	Safety Jacket, Race Quip SFi Multi Layer, Large Red	174.95	134.95
CPXRJS200400305	Safety Jacket, RJS Jacket Elite Blue SFI 32A/1 Large	98.99	83.95
CPXSQ110006	Safety Suit, Race Quip SF-1 Suit, 1 pc, Black, Single Layer	115.95	95.00
CPXSQ112008	Safety Pants, Race Quip SFI-1 Pants, 110 Series, Single Layer, Black, 3X Large	94.95	84.95
CPXRJS8001200	Safety Head Sock, RJS Head Sock, SFI 3.3 Adult White	29.69	24.95
CPXRJS200410307	Safety Pants, RJS Pants, Elite, SFI, 2X Large Blue	88.45	82.45
CPXGFR4101XLGRD	Safety Gloves, G Force Gloves, Single Layer, Adult X Large Red	57.00	47.00
CPXGFR4254090BK	G-Force Crew Size 9 Black Shoe, Gas Oil Resistant	99.00	69.00

S

			WAS	NOW
Screw-In-Studs	CPX3973416	SB Chev 3/8 Hi-Perf Set, Non-Collared	29.00	20.00
Seal Plate	CPXARP934-0007	ARP Cam Drive, SBC Seal Plate, 1/2 Off	37.95	18.95
Shift Improvement Kit	CPXBMM70239	B&M, GM700R4, 4L60	67.12	57.95

SHORT BLOCK SBC 378 C.I.

			WAS	NOW
CPXSB383-FF	SB Chev. 378 C.I. 4-bolt Block, Eagle 4340 Crank, HRC TrackSmart 6.0" H Beam Rods w/ ARP200, Icon Forged F/T 11-1 Pistons, King HP Bearings, HRC Plasma Moly Rings Int. Bal., Pro Assembled, 4.005" x 3.750s - No warranty expressed on implied.		4295.00	3495.00

SPARK PLUG WIRES

			WAS	NOW
CPXMOR73801	Moroso Ultra 40 Race, Universal Straight boot		152.99	109.95
CPXMOR73600	Moroso Ultra 40 Race, Sleeved SBC Non-HEI		246.99	219.95
CPXMOR72000	Moroso Wire Sleeve 25' Blue		101.99	69.95
CPXMOR9765 M	Moroso Mag-Tune Sleeved Race SBC w/o HEI Under Head		109.99	84.95
CPXMOR73614	Moroso Ultra 40 Race Set, 8.65mm, Straight Boots Sleeved		235.99	186.00
CPXMOR9764M	Moroso Magtune 8.0mm, Straight, BBC		109.99	89.95
CPXMOR73617	Moroso Ultra 40 Race, 8.65mm, 90 Degree Boots, Long Sleeved		235.99	186.00
CPXPHLS821	SBC Over v/Cover, Non-HEI Sleeved Race, Phillips		115.99	94.99
CPXPHLS851	BBC Under v/Cover, Over EX. HEI Sleeved Race, Phillips		115.99	94.99

			WAS	NOW
Spool	CPXMGPF510-28	Motive Gear, GM, 8.5, 10 Bolt, 28 Spline	166.95	139.95
Spring Cups	CPXMAN42121-16	Manley Spring O.D. 1.740, Cup 1.680, ID 635,16	92.50	72.50
Starter Pinion Gear	CPXPWM603	Powermaster Hitachi Replacement	24.95	14.95

STARTERS

			WAS	NOW
CPXMSD5096	Advance Power Sys. GM LS Series, Starts HiComp Eng		399.95	349.95
CPXPWM9504	Powermaster 351 w/c Mini 289, 302		235.95	199.95
CPXCVR5056	Ford SB Protorque 1.9HP, 2 or 3 Hole Mt, Manual 3/4 Speed		262.99	175.95
CPXCVR5323OS	CVR Protorque Chev w/ Staggered Mount 168T		218.95	189.95

STUD GIRDLE

			WAS	NOW
CPXJOM1147	Jomar Pro Model /ford 429-460, A-460 Elim. SVO, TFS Heads		322.95	249.95
CPXJOM1153	Jomar Pro Model Pontiac 400-455 Edelbrock		189.95	124.95
CPXJOM1126	Jomar Pro Model Ford 260-351W Dart, World, AFR		182.95	149.95
CPXJOM1128	Jomar Pro Model Ford 260-351W		182.95	149.95
CPXJOM1125	Jomar Pro Model Ford 260-351W Iron, No Nuts		169.95	99.95

			WAS	NOW
Super Sucker	CPXHVH554500-1.1AL	Dominator/King D. 4500, 1" Alum.	139.99	104.95

T

			WAS	NOW
T Bar Wing Nuts	CPXMOR68605	Moroso 1/4-20 Red 4 Pack	38.99	24.95
Tach	CPXAUT233904	10,000 RPM with shift lite 5"	223.95	209.95
Tach	CPXAUT 233911	Autometer Monster, Shift Lite, 0-10,000, 5" Analog, Shift Light	223.98	172.95
Tach	CPXVDOA2C59517134	VDO 10,000 RPM, 5" Electric	126.99	89.99
Timing Chain	CPX3354324	Replacement Roller Chain, Chev BB Racing, True Roller, Dyna Gear	23.95	7.95
Timing Chain	CPX3354208	Pontiac True Roller Chain, Racing Quality, Dyna Gear	29.00	7.95
Timing Pointer (Adj.)	CPXCVRTP3800S	Adjustable SBC 8" 2 pc. Billet	36.99	28.99

T

TIMING SET

			WAS	NOW
CPXSAG78935T-9	SA Gear Billet Roller, LS3 (L92,3 Bolt, 4 Sen)		132.01	89.24
CPXSAG78734R	Chev LS Adjustable LS1/2/6/R/LR4 3 Bolt, 1 Sen		151.91	113.93
CPXSAG78530T-9	SA Gear Billet Ford 429-460,9 Key		108.78	87.02
CPXCLO9-3110A05	Cloyes Hex-A-Just BBG IV, .005 U.S.		193.95	169.95
CPXCLO9-3146A	Cloyes Hex-A-Just SBG Rocket/Dart		172.99	138.36
CPXSAG78535T-9R	Chev LS, 6.0/6.26, 1 Bolt, 4 Sensor, Double Roller Billet Steel		132.01	114.00
CPXSAG7850T-9R	SA Gear, Chrysler 5.7/6.1 HEMI 9 Keyway Billet Steel		193.79	149.95
CPXCLO9-3612X9	Cloyes, Pontiac V-8, Billet Roller, 9 Keyway		145.95	129.95
Timing Tab	CPXPVT54961 BB Chev 8" Chrome		3.29	1.64

			WAS	NOW
Tire Pressure Guage	CPXRDH5000-60	Redhorse 0-60 14" Hose	19.95	12.95
Tire Pressure Guage	CPXLON52004	Longacre 2" 0-60 psi Dial Face, 14" Hose	36.99	26.99
Tire Pressure Guage	CPXLON53036	Longacre 2" 0-100 psi Dial Face 14" Hose	56.99	46.99
Tire Pressure Guage	CPXLON 52033	Long Acre, Glow In Dark, 0-15 17" Hose	69.99	51.45
Traction System	CPXRICLS201030	Powertrax Ext. Grip LS 10 Bolt, 8.5, 30 Spline	761.99	561.99
Traction System	CPXRICLS108028	Powertrax Ext. Grip Ford 8" 28 Spline	645.99	539.95
Trans Dipstick	CPXBTE 223950	BTE Powerglide, Stock Case	57.95	47.00
Trans Kit	CPXBMM50231	B&M Complete Trans in a Box Ford C4 70-82	358.95	318.94
Trans Pak	CPXBMM70235	B&M, GM700R4, 4L60 Kit	144.95	124.95
Trans Pan Blt Kit	CPXSPE2702	Trans Pan Bolt Kit, Kit 12 Point 5/16"-18 x 1/2" 14 pc	12.99	8.99
Trans Pan	CPXMOR42000	Moroso Fab. Aluminum GM Power Glide	259.99	194.95

V

VALVES

			WAS	NOW
CPXMAN10747	Manley SBC Ex. 1.560 4.911 STD, Set		128.07	89.95
CPXMAN11525	Manley BBC Ex. 1.880 3/8 +.100 Sev. Duty , Set		280.00	224.95
CPXMAN11529-1	Manley Ford 429-460 Sev Duty 1.760 Ex. 11/32 STD, ea.		35.14	28.95
CPXMAN11800	Manley BBC 2.190, 5.244L, 11/32, Sev Duty 1		281.12	224.95
CPXMAN11802-1	Manley Ford 429-460 Sev Duty, 2.250 IN. 11/32 STD, ea.		36.30	27.00
CPXMAN11814-8	Manley BBC 2.250, Race Master 11/32 5.344, Set		174.46	147.95
CPXMAN11824-8	Manley SBC Sev Duty Proflo 2.055 +.100, 8 pc		281.12	239.95
CPXMAN11538-8	Manley BBC Race Series 2.190 3/8 Int., 8 pc		290.82	239.99
CPXMAN11737-8	Manley BB Ext. Duty Intonal 1.880 11/32 5.522, 8 pc		482.35	399.00
CPXMAN11474T-8	Manley Titanium SBC 2.055, 11/32, 5.040, 8 pcs		1,114.00	914.00
CPXMAN11426T-8	Manley Titanium SBC 2.150, 11/32, +.500, 8 pcs		1,113.00	914.00
CPXMAN11408T-8	Manley Titanium, SBC, 2.100, 11/32, +.100, 8 pcs		1,152.00	899.00
CPXMAN10754	Manley Streetmaster SBC 2.055, STD		128.56	104.95
CPXREVCL1743	BBC, INT. 2.300, REV. 11/32 Stem, 5.560L, 5pcs, Super Duty		110.00	49.95
CPXREVCL1744	BBC 2.325 11/32, OAL 5.475 6pcs - 1/2 Off ea.		22.95	11.45
CPXREVCL1609	SBC 1.625 EX. SuperDuty +.150 8pcs - 1/2 Off		240.00	120.00
CPXREVCL1175	Chev LS1/6/3/92 2.055 int. 8MM 4.915L, ea.		19.99	14.95

			WAS	NOW
Valve Body Kit	CPXPMAPA70416	GM TH700R4, PA	145.77	105.77

VALVE COVERS & ACCESSORIES

			WAS	NOW
CPXPVT59237	Valve Cover, Ford SB, Chrome, w/ Baffles, Power Products		32.95	26.95
CPXARP100-7505	Valve Cover Bolt Kit, ARP Steel Valve Covers Hex 8pk		9.99	7.99
CPXFEL1643	Valve Cover Gaskets, Ford 429/460 Fel Pro, Performance, Pair		44.99	38.95

V

VALVE LOCKS

		WAS	NOW
CPX4135	VTO, Forged Steel, 7 Degree Valve Locks, 3/8 Valve Stem, Set of 16, Pair, was \$14.95, now \$5.82 (10 Sets \$1.95 ea)	0.00	5.82
CPX4438	VTO, Forged Steel, 10 Degree Valve Lock, 3/8 Valve Stem, was \$17.95, now \$4.95 (10 sets \$2.95 ea)	0.00	4.95
CPXPAC-L8113	PAC LS 8MM Machined Steel 8MM STD HT	88.00	61.60

VALVE SEALS

		WAS	NOW
CPXHRC93321	VTO Ultimate PC, 3/8 for .531, Nitro, Alcohol Tolerant, Set of 16	18.99	8.99
CPXHRC93320-100	VTO Ultimate PC, 3/8 for .531, Nitro, Alcohol Tolerant, Pack of 100 pcs (\$3.62 per set)	0.00	22.60

VALVE SPRINGS

		WAS	NOW
CPXPAC-1395	PAC 1.574 O.D. 265 @ 2.0, 705 @ 1.20, 800 Lift Oval Track	576.99	403.95
CPXPAC-1364	PAC 1.681 O.D. Triple 525 @ 2.300, 1365 @ 1.300 Drag	600.00	500.00
CPXPAC-1355	PAC 1.500 O.D. 420 @ 2.175, 1200 @ 1.175, Oval T	576.00	403.20
CPXPAC-1370	PAC 1.550 O.D. 555 @ 2.350, 1433 @ 1.300	576.00	403.20
CPXCCA924-16	Comp Cams, Dual 1.509 OD 112 @ 1.900, 335 @ 1.200	154.99	131.95
CPXCCA959-16	Comp Cams Hi-Tech 1.645 @ O.D., 236 @ 2.0, 671 @ 1.25	465.00	375.00
CPH98116	LS1/2/6 1.305, 145 @ 1.80, 385 @ 1.150, CB 1.100	137.99	190.39
CPH98117	Beehive 1.014/1.450, 118 @ 1.95, 375 @ 1.38, CB 1.32	169.99	135.99
CPH98220	Pac 1.260m 140 @ 1.75, 410 @ 1.20, CB 1.115	259.95	207.96
CPH98221	Pacaloy Nitrided, 1.260, 140 @ 1.75, 410 @ 1.20, CB 1.115	399.99	319.99
CPH98335	LS1/2/6 Dual 1.300, 250 @ 1.80, 860 @ 1.050, CB .985	659.99	527.99
CPH98815	Pacaloy SP 1.550, 250 @ 2.0, 765 @ 1.20, CB 1.150	619.99	495.99
CPH98824	Pacaloy 1.625, 275 @ 2.0, 810 @ 1.150, CB 1.100	432.99	346.39
CPH98825	Pacaloy 1.550, 250 @ 2.0, 710 @ 1.25, CB 1.035	428.99	343.19
CPH98875	Pacaloy 1.575, 265 @ 2.0, 705 @ 1.20, CB 1.150	619.99	495.99
CPH98893	Pacaloy 1.681, 500 @ 2.20, 1.256 @ 1.30, CB 1.100	672.99	538.39
CCA917-16	Comp Cams, 1.550 Dual, to 690 Lift, 566 Rate, 1.050 CB, Maxlift .690	181.95	164.95

		WAS	NOW	
Vibration Dampening Material	CPXDSN050223	4mm, 12-1/2" x 24", 10 Sheets	154.99	124.95
Vibration Dampening Material	CPXDSN050222	4mm, 12-1/2" x 24", 5 Sheets	91.99	73.95

W

WATER PUMP

		WAS	NOW
CPXEDE8833	Edelbrock Circle Track Ford 289-351 W Victor Series	335.95	289.95
CPXWEI9212	Weiand, Action Plus, Short Hi Vol. BBC	179.95	139.95
CPXTFF1594NF	Tuff Stuff, Hi Vol, Mustang 86-93 5.0L, DS Inlet	89.95	78.95
CPXPUT73954	Power products Ford 351W 70-87 Driver Inlet Alum	109.95	89.95
CPXPRP6650	PRP Remote Elec. w/p Black 50 G.P.M.	285.99	225.00
CPXMOR63547	Moroso, Billet Alum., Electric, 30-37 GPM, BB Chev	531.99	431.99
CPXCVR8554BK	CVR Electric, 55 GPM, BB Chev., Black Anodized	335.99	281.95
CPXPFM66225B	Electric Pro Form +35gpm. SB Chev, Blue	193.99	169.95

		WAS	NOW	
Water Pump Fittings	CPXPRP6100	Remote Hose Adpt. 1.25" For Electric	32.99	16.95
Water Pump Fittings	CPXPRP6101	Remote Hose Adapter 1.50" For Electric	32.99	16.95
Water Temp. Gauge	CPXAUT2355	Autometer, 100-280 Degree, Electric, Autogauge	46.99	34.99

W

WIRING

			WAS	NOW
CPXMOR63543	Elect w/ Phase Adapter 1.0 NPT to 1 3/4" Hose		36.99	19.95
CPXMSD8187	Deutsch Wiring fCon. 4-pin 12-14 Gauge		65.95	52.95
CPXMSD8186	Deutsch Wiring fCon. 12-pin 16 Gauge		39.95	29.95
CPXMSD8185	Deutsch Wiring fCon. 8-pin 16 Gauge		34.95	24.95
CPXDAY119006	Wiring Harness, Daytona Sensors Smart Spark LS 2/7		149.95	129.95

			WAS	NOW
Wire Loom	CPXMRG9753	Each has 4 Dividers, Tall, Chrome, Pair	5.95	1.97
Wire Separator	CPXMRG9750	Chrome, 7 & 8 mm, 2-Wire, Short, Pair	5.95	1.97
Wire Separator	CPXMRG9751	Chrome, 7 & 8 mm, 4-Wire, Pair	5.95	1.97
Wire Separator	CPXMRG9752	Chrome, 7 & 8 mm, 2-Wire, Tall, Pair	5.75	1.87
Wrist Pins	CPXHRC92298	Tool steel .927"x2.950" 125-180", Tapered wall, 143 grams. Set of 8	168.00	89.00
Wrist Pins	CPXELGP1019	H-11 Tool steel .990" O.D. .090 wall, 2.930" APR 96 grams, Each 1/2 off	19.98	9.99
Wrist Pins	CPXELGP1264	1081 cold rolled steel .927" O.D. .150 wall, 2.950" APR 141 grams, Each 1/2 off	9.99	3.99
Wrist Pins	CPXELGP1284	H-11 tool steel .912" O.D. .090 wall, 2.500" APR 74.5 grams, Each 80% off	16.99	3.39
Wrist Pins	CPXELGP1995	E H-11 tool steel .990" O.D. 130 wall, 2.930" APR 130 grams, Each 35% off	19.98	12.99
Wrist Pins	CPX990-2930-18-51S	JE Series, 51, .990, 2.930L, 174 grams	122.88	98.00

WRIST PINS

			WAS	NOW
CPXHRC92298	Tool Steel .927" x 2.950" 125-180", Tapered Wall, 143 Grams, Set of 8, 80% off		168.00	89.00
CPXELGP1019	H-11 Tool Steel, .990" O.D., .090 Wall, 2.930" APR 96 Grams, each 80% off		19.98	3.99
CPXELGP1264	1018 Cold Rolled Steel, .927" O.D., .150 Wall, 2.950" APR, 141 Grams, each 80% off		9.99	1.99
CPXELGP1284	H-11 Tool Steel, .912" O.D., .090 Wall, 2.500" APR, 74.5 Grams, each 80% off		16.99	3.39
CPXELGP1995	H-11 Tool Steel, .990" O.D., .130 Wall, 2.930" APR 130 Grams, each 80% off		19.98	3.99
CPX990-2930-18-51S	JE Series, 51, .990, 2.930L, 174 Grams, 80% off		122.88	98.00

BRAND NEW RETURNS

ALL SALES FINAL!

			WAS	NOW
Air Cleaner	CPXPVT52095	Power Products 14" low profile, black, small dent on side	29.99	19.99
Bearings	CPXACL5M429H	STD. ACL race, SBC, S/J mains, minor scuffing	89.95	55.99
Engine Mounts	CPXPVT27-MM500	SB Chev, steel, display V8	39.95	20.99
Polylocks	CPX4601-16	3/8-24 .600 O.D. set Comp Cams	32.95	19.95
Pushrods	CPXHRC95122-8-11450	Howards Moly, .80W, 11.450L, 3/8, 8pcs Hardened moly	103.92	46.25
Pushrods	CPXHRC95499-8-9700	Howards one piece 9.700", .080, 3/8, 8pcs Hardened moly	119.92	54.95
Pushrods	CPXHRC95499-8-9900	Howards one piece 9.900", .080, 3/8, 8pcs Hardened moly	119.92	54.95
Pushrods	CPXMRP516-9500	BC Manton chrome mly, 9.380L, OAL 9.500 cup, ball, 5/16, 8pcs	90.00	40.00
Oil Pump	CPXME110555ST	Melling Shark tooth SBC. New but installed	194.42	169.95
Timing Set	CPXHRC94305-5	Howards BBC - .005 billet, 9 key, new but installed	124.95	99.00
Polishing Wool	CPXSTA726020	80 Grit 1/8"	2.29	1.75

**The following pages are examples
of our everyday low prices!**

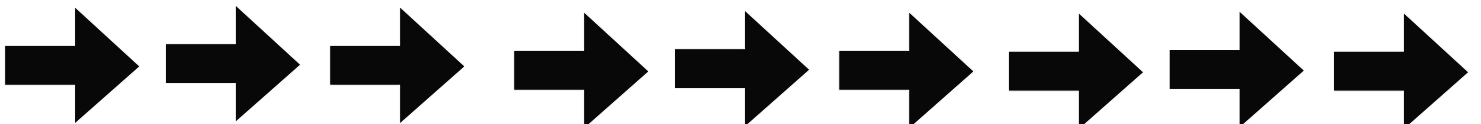

POWER PRODUCTS

Top of Engine Kits

Specifically designed to deliver the performance you want, at a money saving price. Multiple packages with intake runner size and intake manifold styles to choose from. These complete kits feature a pair of fully assembled Power Products aluminum heads, great for performance street or street/strip applications. Included is an aluminum intake, head and intake bolts. Head, intake, exhaust, valve cover and carb gaskets are also included. Save time and money! Everything you need in one kit.

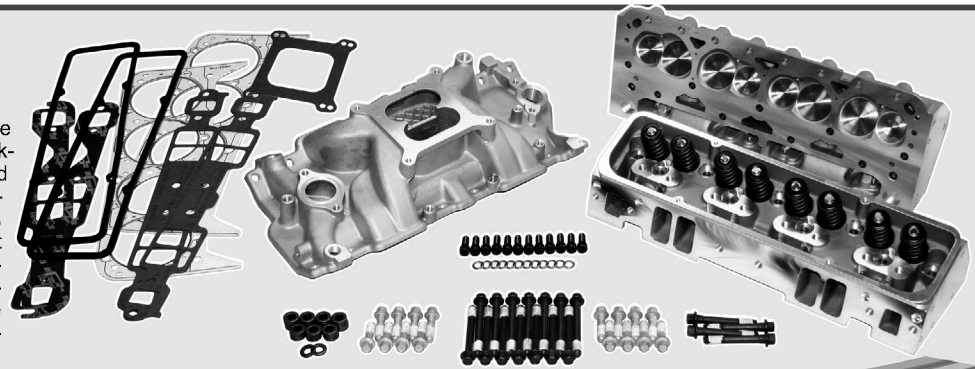

- Power Products Fully Assembled Aluminum Heads • Dual Plane, Dual Plane Air Gap or Single Plane Intake
- ARP Cylinder Head Bolt Set • Power Products Intake Bolt Set
- Cylinder Head Gaskets • Valve Cover Gaskets • Exhaust Gaskets • Intake Gaskets • Carburetor Gasket



Chev SB Top of Engine Kits (205cc Intake Runner)

1.250" Hydraulic/Mechanical Flat Tappet Valve Springs	
PVT29-990001w/ Dual Plane Intake Manifold, Straight Plug.....	\$1279.00
PVT29-990011.....w/ Dual Plane Intake Manifold, Angle Plug.....	\$1279.00
PVT29-990003w/ Air Gap Dual Plane Intake Manifold, Straight Plug.....	\$1329.00
PVT29-990013w/ Air Gap Dual Plane Intake Manifold, Angle Plug.....	\$1329.00
1.470" Hydraulic Roller/Mechanical Flat Tappet Valve Springs	
PVT29-990002w/ Dual Plane Intake Manifold, Straight Plug.....	\$1349.00
PVT29-990012w/ Dual Plane Intake Manifold, Angle Plug.....	\$1349.00
PVT29-990004w/ Air Gap Dual Plane Intake Manifold, Straight Plug.....	\$1399.00
PVT29-990014w/ Air Gap Dual Plane Intake Manifold, Angle Plug.....	\$1399.00
PVT29-990006w/ Single Plane Intake Manifold, Straight Plug.....	\$1469.00
PVT29-990016w/ Single Plane Intake Manifold, Angle Plug.....	\$1469.00
1.540" Mechanical Roller Valve Springs	
PVT29-990007w/ Single Plane Intake Manifold, Straight Plug.....	\$1499.00
PVT29-990017w/ Single Plane Intake Manifold, Angle Plug.....	\$1499.00

Chev SB Top of Engine Kits (220cc Intake Runner)

1.470" Hydraulic Roller/Mechanical Flat Tappet Valve Springs	
PVT29-990106w/ Single Plane Intake Manifold, Straight Plug, 2.020"1.600".....	\$1489.00
PVT29-990116w/ Single Plane Intake Manifold, Angle Plug, 2.020"1.600".....	\$1489.00
1.540" Mechanical Roller Valve Springs	
PVT29-990107w/ Single Plane Intake Manifold, Straight Plug, 2.020"1.600".....	\$1639.00
PVT29-990117w/ Single Plane Intake Manifold, Angle Plug, 2.020"1.600".....	\$1639.00
PVT29-990109w/ Single Plane Intake Manifold, Straight Plug, 2.055"1.600".....	\$1639.00
PVT29-990119w/ Single Plane Intake Manifold, Angle Plug, 2.055"1.600".....	\$1639.00
PVT29-990111w/ Single Plane Intake Manifold, Straight Plug, 2.080"1.600".....	\$1639.00
PVT29-990121w/ Single Plane Intake Manifold, Angle Plug, 2.080"1.600".....	\$1639.00

Chev BB Top of Engine Kits (310cc Intake Runner)

1.540" Hydraulic Roller/Mechanical Flat Tappet Valve Springs	
PVT29-990216w/ Single Plane Intake Manifold.....	\$1999.00
1.625" Mechanical Roller Valve Springs	
PVT29-990217w/ Single Plane Intake Manifold.....	\$2149.00
1.625" Mechanical Roller Valve Springs	
PVT29-990227w/ Single Plane Intake Manifold.....	\$2359.00

Dodge/Chrysler SB LA Top of Engine Kits (171cc Intake Runner)

1.250" Hydraulic Flat Tappet Valve Springs	
PVT29-990083w/ Air Gap Dual Plane Intake Manifold.....	\$1849.00
1.470" Hydraulic Roller Valve Springs	
PVT29-990084w/ Air Gap Dual Plane Intake Manifold.....	\$1929.00

Ford 289-302 Top of Engine Kits (185cc Intake Runner)

1.250" Hydraulic/Mechanical Flat Tappet Valve Springs	
PVT29-990041w/ Dual Plane Intake Manifold.....	\$1399.00
PVT29-990043w/ Air Gap Dual Plane Intake Manifold.....	\$1459.00
1.470" Hydraulic Roller/Mechanical Flat Tappet Valve Springs	
PVT29-990042w/ Dual Plane Intake Manifold.....	\$1469.00
PVT29-990044w/ Air Gap Dual Plane Intake Manifold.....	\$1539.00

Ford 289-302 Top of Engine Kits (200cc Intake Runner)

1.250" Hydraulic/Mechanical Flat Tappet Valve Springs	
PVT29-990141w/ Dual Plane Intake Manifold.....	\$1569.00
PVT29-990143w/ Air Gap Dual Plane Intake Manifold.....	\$1579.00
1.470" Hydraulic Roller/Mechanical Flat Tappet Valve Springs	
PVT29-990144w/ Air Gap Dual Plane Intake Manifold.....	\$1649.00
PVT29-990146w/ Single Plane Intake Manifold.....	\$1729.00

1.550" Mechanical Roller Valve Springs

PVT29-990147w/ Single Plane Intake Manifold.....	\$1819.00
--	-----------

Ford 351W Top of Engine Kits (185cc Intake Runner)

1.250" Hydraulic/Mechanical Flat Tappet Valve Springs	
PVT29-990051w/ Dual Plane Intake Manifold.....	\$1499.00
1.470" Hydraulic Roller/Mechanical Flat Tappet Valve Springs	
PVT29-990052w/ Dual Plane Intake Manifold.....	\$1589.00

Ford 351W Top of Engine Kits (200cc Intake Runner)

1.250" Hydraulic/Mechanical Flat Tappet Valve Springs	
PVT29-990151w/ Dual Plane Intake Manifold.....	\$1599.00
1.470" Hydraulic Roller/Mechanical Flat Tappet Valve Springs	
PVT29-990152w/ Dual Plane Intake Manifold.....	\$1679.00
PVT29-990156w/ Single Plane Intake Manifold.....	\$1789.00
1.550" Mechanical Roller Valve Springs	
PVT29-990157w/ Single Plane Intake Manifold.....	\$1879.00



Chev SB Top End Engine Kits

SHP (Aluminum Heads) Top End Combos (dual plane intake)

DRT01411132.....200/64cc, Straight Plug, 2.02/1.60, w/1.437 Springs.....	\$1799.99
--	-----------

Pro-1 (Aluminum Heads) Top End Combos

DRT01210002.....215/64cc Angle Plug, 2.05/1.60, w/1.437 Springs.....	\$2944.99
DRT01210003.....230/64cc Angle Plug, 2.08/1.60, w/1.550 Springs.....	\$3099.99



Top End Engine Kits

Don't spend hours finding the parts and pieces you need to get what you want from your engine. Dart has already done the work for you with their Top-End engine kits. These kits are specifically designed to deliver the performance you want, at a money saving price. You get fully assembled Dart cylinder heads, Dart chrome valve covers, a Dart single plane (except as noted) intake manifold, all gaskets needed for installation, spark plugs, and head bolts for a worry-free, proven performance setup in one complete kit!



Chev BB Top End Engine Kits

Pro-1 (Aluminum Heads) Top End Combos

DRT01220007.....325/118cc, w/1.550 Springs.....	\$4953.93
DRT01220008.....345/118cc, w/1.625 Springs.....	\$5187.29

Ford SB Top End Engine Kits

Pro-1 (Aluminum Heads) Top End Combos (dual plane intake)

DRT01250102.....170/62cc 302 8.200", 2.02/1.60, w/1.437 Springs.....	\$3099.73
DRT01251122.....195/62cc 351W 9.500", 2.02/1.60, w/1.437 Springs.....	\$3099.73

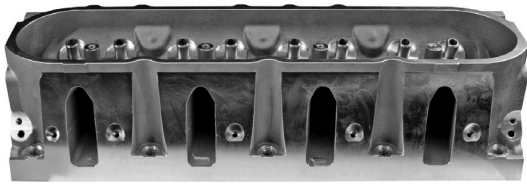

POWER PRODUCTS

Power Plus GM LS1 Cathedral Port Heads

All new castings using the latest technology. Chambers designed for improve flow. 212cc cathedral port intake runners with 57cc combustion chambers. Heat-treated T6 aluminum. All machined surfaces are performed by CNC, including bolt holes, to achieve extreme accuracy in finishing. OEM bolt patterns are used for compatibility. **Assemblies** feature 2.020"/1.570" stainless valves, Howards Cams valve springs and chrome moly steel retainers.

- PVT54420.....LS1 212cc/57cc, Bare.....\$739.90pr.
- PVT54420K20.....LS1 212cc/57cc, Assembled Hyd. Roller Beehive to .625" Lift.....\$1079.95pr.

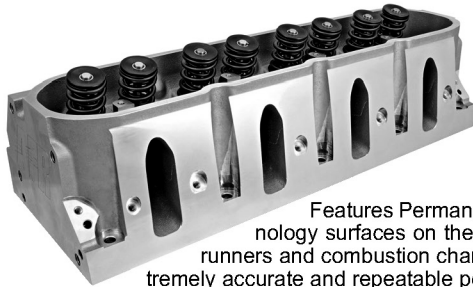

LS1 Enforcer Cathedral Port Heads

Features Permanent Mold "As-Cast" Technology surfaces on the intake runners, exhaust runners and combustion chambers that allows for extremely accurate and repeatable port location and performance. This budget friendly head is perfect for your OEM or mild Street Performance engine operating below 6300 RPM. They come fully assembled with the identical components found in our higher end CNC ported cylinder heads; such as PAC Racing springs, viton valve seals, machined bead valve locks (not stamped), hardened spring seats and one piece 8mm 21 4N Stainless Steel valves.

- AFR1501.....LS1 210cc/64cc, Assembled.....\$1486.00pr.

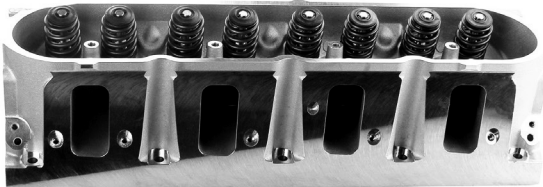

POWER PRODUCTS

Power Plus LS3 Square Port Heads

Refined 280cc intake ports for throttle response and upper end power. Designed to significantly increase horsepower and torque throughout a wide power band. 70cc chambers designed for 4.000" or larger bores. Enhanced precision cast from A356 aluminum. Designed to use most LS3 style intake manifolds and components. Features include 8mm bronze manganese guides, hardened valve seats, large spring seats, and multi-angle valve job. **Assemblies** feature 2.165"/1.600" stainless valves, Howards Cams valve springs and chrome moly steel retainers.

- High flowing 280cc intake ports
- Machined with 2.165" x 1.600" valve job
- 6 bolt per cylinder capability
- Compatible with all LS3 intake manifolds & components

- PVT54424.....LS3 280cc/70cc, Bare.....\$799.90pr.
- PVT54424K20.....LS3 280cc/70cc, Assembled Hyd. Roller Beehive to .625" Lift.....\$1179.95pr.
- PVT54424K25.....LS3 280cc/70cc, Assembled Hyd. Roller Dual to .650" Lift.....\$1299.95pr.



LS Head Bolt Kits

Wide area flanged head eliminates the need for valvetrain removal to facilitate cylinder head retorquing. 180,000 psi and kits include hardened parallel-ground washers.

- ARP134-3609.....Hex, 4.8, 5.3, 6.0L, up to 2003.....\$207.99
- ARP134-3610.....Hex, 4.8, 5.3, 6.0L, 2004 & Later.....\$144.99

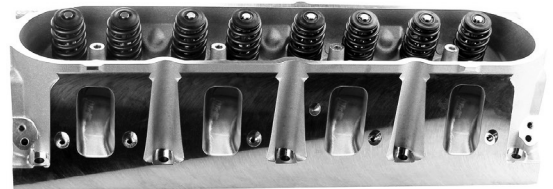

POWER PRODUCTS

Power Plus LS3 CNC Competition Ported Square Port Heads

Fully CNC machined for the perfect street/strip combination. The 70cc CNC'd chambers are designed for 4.000" or larger bores. Precision cast from A356 aluminum. Designed to use most LS3-style intake manifolds and components. Features include 8mm bronze manganese guides, hardened valve seats, large spring seats, and multi-angle valve job. **Assemblies** feature 2.165"/1.600" stainless valves, Howards Cams valve springs and chrome moly steel retainers.

- 276cc CNC'd Intake Ports Flow up to 339 cfm
- CNC Ported Exhaust Ports Flow up to 239 cfm
- Machined with 2.165" x 1.600" Valve Job
- 6 Bolt Per Cylinder Capability
- Compatible with All LS3 Intake Manifolds & Components

- PVT54464.....LS3 276cc/70cc, Bare.....\$1299.90pr.
- PVT54464K20.....LS3 276cc/70cc, Assembled Hyd. Roller Beehive to .625" Lift.....\$1679.95pr.
- PVT54464K25.....LS3 276cc/70cc, Assembled Hyd. Roller Dual to .650" Lift.....\$1789.95pr.

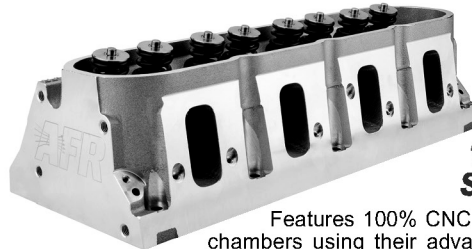

LS3 Mongoose 100% CNC Ported Square Port Heads

Features 100% CNC ported intake, exhaust and chambers using their advanced engineering and flow techniques to produce the ultimate Rectangle Port head available today. At .650" lift they will flow 377 intake and 251 exhaust at 28" of water. A356 aluminum castings, titanium retainers and the highest quality components throughout. They're designed for 4.000 or larger bore applications up to 454 CI, operating up to 7000 RPM. Emissions legal for 2008 to 2015 vehicles under CARB #D-250-5. **Assemblies** feature 2.165"/1.600" stainless steel valves, PAC 1.270" dual hydraulic roller valve springs (to .650" lift), titanium retainers and 8mm bead lock valve locks.

- 100% CNC Ported Intake Ports
- Intake Ports Flow up to 384 cfm
- 100% CNC Ported Exhaust Ports
- CNC Ported Exhaust Ports Flow up to 255 cfm
- 100% CNC Ported Combustion Chambers
- 2.165" x 1.600" 8mm Bead Lock Valves
- 4 or 6 Bolt Per Cylinder Capability
- Competition 5-angle Valve Job
- Compatible with All LS3 Intake Manifolds & Components

- AFR1845.....LS3 260cc/69cc, Assembled, 4-Bolt Pattern.....\$3324.00pr.
- AFR1840.....LS3 260cc/69cc, Assembled, 6-Bolt Pattern.....\$3324.00pr.



Competition Products®
Plastic Head & Crank Bags

Really Heavy-Duty! Super thick. Four times thicker than standard storage bags! Heavy mil see-through clear plastic. Great for short or long term storage. Keeps parts dust and moisture free.

- CMP8100.....Head/Crank Bag, Single.....\$1.49
- CMP8100-5.....Head/Crank Bags, Pack of 5.....\$5.99
- CMP8100-10.....Head/Crank Bags, Pack of 10.....\$10.49

TIMING SETS



DOUBLE ROLLER BILLET STEEL TIMING SETS / BEL DRIVES

DOUBLE ROLLER BILLET STEEL TIMING SETS WITH IWIS SEVERE APPLICATION CHAIN

The IWIS chain, designed and widely known for its strength and durability in the most extreme conditions. This precision made special heat-treated high strength steel chain is the choice of the most serious engine builders. These sets include a CNC machined billet steel cam sprocket with lightening holes, a heat-treated crank sprocket with 9-keyways and a black oxide coating and Torrington thrust bearing.



94700	Chevrolet SB 55-96, 265-400, except Factory Roller Cam, 9-Keyway
94705	Chevrolet BB Mark IV 65-98, 396-454, 9-Keyway
94712	Ford 302/351W 72-02 Factory 2pc eccentric, 9-Keyway

BELT DRIVE TIMING SETS

The Ultimate Camshaft Drive for your competition engine. Manufactured from the finest materials on state of the art CNC machining centers. These belt drives will deliver reduced valve train harmonics, precise valve timing and longer valve spring life. A fully rollerized thrust housing means less friction. A full 20° of Valve Timing adjustment.

- **Designed for Reduced Valve Train Harmonics**
- **Precise Valve Timing**
- **Simple valve timing adjustments in minutes**
- **Quick and easy cam changes**



94900	Chevrolet SB 55-96, 265-400, except Factory Roller Cam
94902	Chevrolet SB 55-96, 265-400, Raised Cam (.391")
94980	Optional Timing Cover for 94900/94902
94908	Chevrolet Gen III 97-05, LS1/6 3-Bolt
94909	Chevrolet Gen III 97-05, LS1/6 3-Bolt, Dart Thrust
94988	Belt & Seal Kit, Chevrolet LS, Designed for use with 94908 or 94909
94998	Cam Sensor Kit, Chevrolet LS, Designed for use with 94908 or 94909
94905	Chevrolet BB Mark IV 65-98, 396-454
94930	Chrysler SB 64-03, 318-360
94940	Chrysler BB 58-78, 383-440/426 Hemi, Three bolt
94942	Chrysler BB 58-78, 383-440/426 Hemi, Three bolt, Raised Cam
94910	Ford SB 72-02, 302/351W
94988	Belt & Seal Kit, Ford SB 72-02, 302/351W, Designed for use with 94910
94925	Ford FE 63-73, 352-428



Heavy Duty Timing Sets

Cloyes premium heavy duty timing chain sets are an economical top-quality replacement for street and mild performance applications. Three piece sets include iron gears and top quality heavy-duty chains.



CLOC3001K.....Chev SB.....	\$16.99
CLOC3064K.....Chev 305-350 w/Factory Roller Cam.....	\$20.99
CLOC3011K.....Chev BB.....	\$22.99



Double Roller Speed Sets

High quality and reliability on a budget. Features a cam sprocket machined from cast iron, billet steel induction hardened crank sprocket and a .200" dia. double roller chain for small blocks or a .222" for big blocks.



CLOC3023K.....Chev SB, Single Keyway.....	\$25.99
CLOC3023X.....Chev SB, 3-Keyway.....	\$28.99
CLOC3092*.....Chev 305-350 w/Factory Roller Cam.....	\$63.99
<small>*1/2" pitch single roller chain</small>	
CLOC3024K.....Chev BB, Single Keyway.....	\$29.99
CLOC3024X.....Chev BB, 3-Keyway.....	\$45.99
CLOC3054X.....Ford SB '62-'84, 3-Keyway.....	\$57.99



Double Roller Timing Sets



These three piece sets are hand matched for quality and reliability. Features a premium double roller chain for extended life. Cast iron cam sprocket and a 3 keyway crank sprocket offers a +4°, 0°, -4° cam adjustment.

HRC94200.....Chev SB.....	\$42.95
HRC94205.....Chev BB.....	\$51.95
HRC94230.....Chrysler SB.....	\$45.95
HRC94210.....Ford 289-302, 351W '65-'72.....	\$49.95
HRC94212.....Ford 302, 351W '73-'02.....	\$42.95



S.A. Gear Double Roller 250 Timing Sets

These hand matched sets feature a seamless double roller chain with oversize .250" dia. rollers, cast cam sprocket and a 3-keyway crank sprocket with +4/-4 cam adjustment.

SAG78118.....AMC V8 290-401.....	\$64.34
SAG78100.....Chev SB.....	\$51.28
SAG78100T-9.....Chev SB w/Torrington Bearing 9-keyway.....	\$67.13
SAG78150.....Chev 305-350 w/Factory Roller Cam.....	\$57.05
SAG78110.....Chev BB.....	\$54.58
SAG78110T-9.....Chev BB w/Torrington Bearing 9-keyway.....	\$69.36
SAG78103.....Chrysler SB.....	\$63.15
SAG78104.....Chrysler BB, Single Bolt.....	\$63.15
SAG78125.....Chrysler BB, 3-Bolt.....	\$70.99
SAG78120.....Ford 289-302, 351W '65-'72.....	\$61.38
SAG78151.....Ford 302, 351W '73-'88.....	\$60.92
SAG78121.....Ford 351C/M/400.....	\$71.46
SAG78108.....Ford FE 390-427.....	\$58.76
SAG78130.....Ford 429-460.....	\$72.55
SAG78113.....Oldsmobile V8.....	\$67.13
SAG78112.....Pontiac V8.....	\$62.39

Replacement Chains	
SAG3DR-58.....Fits: SAG78100, 78120, 78150 & 78151.....	\$18.69
SAG3DR-66.....Fits: SAG78104, 78110, 78125 & 78130.....	\$23.51



Advance & Retard Cam Bushings

Requires drilling a 13/32" hole in timing gear.	
HRC94505.....0°, 2°, 4°, 6°, 8°.....	\$19.99
HRC94510.....0°, 1°, 3°, 5°, 7°.....	\$19.99



Race Roller Timing Kits w/Torrington

Fully machined steel crankshaft sprocket with 3-keyways. Cast camshaft sprocket machined for torrington thrust bearing. True race style .250" double roller chain. Kit includes captive torrington bearing, roller thrust button and camshaft lock kit.



MAN73141.....Chev SB '55-'78.....	\$127.38
MAN73151.....Chev SB '79-Up.....	\$127.38
MAN73142.....Chev BB.....	\$140.24



S.A. Gear Billet Steel Double Roller Timing Sets

These competition timing sets feature fully machined billet gears. They include a press fit roller thrust bearing and a large .250" diameter seamless double roller chain. They are available with either 3 or 9-keyway crank gear.



SAG78500T.....Chev SB, 3-Keyway.....	\$85.76
SAG78500T-9.....Chev SB, 9-Keyway.....	\$95.05
SAG78500T-9-005 Chev SB (.005 undersized), 9-Key.....	\$98.22
SAG78500T-9-010 Chev SB (.010 undersized), 9-Key.....	\$98.22
SAG78533T-9.....Chev LS1/6 '97-'04, 9-Keyway.....	\$123.56
SAG78934T-9*.....Chev LS2/LSR/LR4 (3-Bolt, 1 Sensor).....	\$111.55
SAG78936T-9*.....Chev LS3/L92 (3-Bolt, 4 Sensor).....	\$111.55
SAG78535T-9R.....Chev LS3 6.0L, 6.2L (1-Bolt, 4 Sensor).....	\$132.01
SAG78935T-9*.....Chev LS3 6.0L, 6.2L (1-Bolt, 4 Sensor).....	\$111.55
<small>*Single .334" roller, fits OE cover with no modification.</small>	
SAG78510T.....Chev BB, 3-Keyway.....	\$89.69
SAG78510T-9.....Chev BB, 9-Keyway.....	\$102.44
SAG78537T-9**.....Chev BB, Gen 6, 9-Keyway.....	\$106.67
<small>**Will fit under most OE timing covers.</small>	
SAG78505T-9R.....Chrysler 5.7/6.1L Hemi.....	\$193.79
SAG78520T-9.....Ford 289-351W '65-'72, 9-Key.....	\$102.44
SAG78551T-9.....Ford 302-351W '73-'02, 9-Key.....	\$104.03
SAG78530T-9.....Ford 429-460, 9-Keyway.....	\$108.78

POWER PRODUCTS Camshaft Lock Plate & Bolt Kit

Helps Prevent costly damage to the valvetrain. Lock installs behind special bolts. Simply torque bolts properly and bend tabs to lock bolts in place.

PVT27-8161.....Chev V8/90° V6..... \$3.79



Billet Steel Timing Sets



Premium SAE 1144 billet steel machined on state-of-the-art CNC equipment. Ensures consistent quality and eliminates the dreaded "run-out" found on inferior products. Sets include a 9-keyway crank sprocket, along with a .250" diameter True® Roller chain.

CLO9-3500TX9.....Chev SB, w/Torrington Bearing.....	\$79.99
CLO9-3600TX9.....Chev SB, w/Pre. High RPM Chain.....	\$125.99
CLO9-3545X9.....Chev SB (w/Factory Roller Cam).....	\$87.99
CLO9-3546TX9.....Chev SB Rocket/Dart, w/Torrington Bearing.....	\$84.99
CLO9-3510TX9.....Chev BB (Mark IV), w/Torrington Bearing.....	\$105.99
CLO9-3525TX9.....Chrysler BB (3-Bolt), w/Torrington Bearing.....	\$126.99
CLO9-3535X9.....Ford 221-351W (1pc Fuel Eccentric).....	\$89.99
CLO9-3522X9.....Ford 429-460.....	\$96.99
CLO9-3513X9.....Oldsmobile V8.....	\$95.99
Replacement Chains	
CLO9-130.....9-3500TX9, 9-3535X9, 9-3545X9.....	\$50.99
CLO9-134.....9-3510TX9, 9-3522X9, 9-3525TX9.....	\$62.99



CLOYES Thrust Bearings

Captured needle bearing assemblies. .150" thick. Anti-friction block protector.

CLO9-220.....Chev SB/BB, Chrysler BB..... \$15.99



Double Roller Billet Steel Timing Sets

These pro billet timing sets are designed for accuracy and long life. Lightweight by design, these sets feature a billet steel cam sprocket with lightening holes, a heat-treated crank sprocket with 9-keyways, and a black oxide coating. The chain is an upgraded large .250" diameter roller. Roller thrust bearing included.

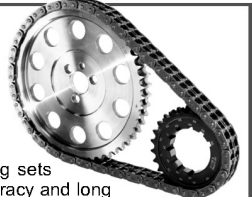

HRC94300.....Chev SB.....	\$115.95
HRC94300-5.....Chev SB (.005 undersized).....	\$125.95
HRC94300-10.....Chev SB (.010 undersized).....	\$125.95
HRC94301.....Chev 305-350 w/Factory Roller Cam.....	\$125.95
HRC94303.....Chev SB w/BB Snout.....	\$119.95
HRC94302(C).....Chev SB Dart/Rocket Block.....	\$119.95
HRC94304.....Chev LS1/6 (3-Bolt).....	\$149.95
HRC94304.....Chev LS2/LSR/LR4 (3-Bolt, 1 Sensor).....	\$159.95
HRC94307.....Chev '06 LS3 6.0L, '07 L92 6.2L (3-Bolt).....	\$159.95
HRC94306.....Chev '07-'10 LS3 6.0L, '08-'10 6.2L (Single).....	\$159.95
HRC94305.....Chev BB.....	\$125.95
HRC94305-5.....Chev BB (.005 undersized).....	\$135.95
HRC94305-10.....Chev BB (.010 undersized).....	\$135.95
HRC94309.....Chev BB Gen 6.....	\$129.95
HRC94330(A).....Chrysler SB, Chry 392 Hemi.....	\$127.95
HRC94332(B).....Chrysler 5.7/6.1L Hemi.....	\$229.95
HRC94335(A).....Chrysler BB (Single Bolt).....	\$125.95
HRC94340.....Chrysler BB (3-Bolt).....	\$135.95
HRC94310.....Ford 289-302, 351W '65-'72.....	\$125.95
HRC94312.....Ford 302, 351W '73-'02.....	\$127.95
HRC94312-5.....Ford 302, 351W '73-'02 (.005 undersized).....	\$137.95
HRC94320.....Ford 351C/M/400.....	\$135.95
HRC94325.....Ford FE 390-427.....	\$129.95
HRC94315.....Ford 429-460.....	\$132.95
HRC94345(B).....Pontiac V8.....	\$129.95

Single Roller Billet Steel Timing Sets	
for GM LS Applications (No Machining Required)	
HRC94354.....Chev LS1/2/6/RLR4 (3-Bolt).....	\$135.95
HRC94357.....Chev '06 LS3 6.0L, '07 L92 6.2L.....	\$135.95
HRC94356.....Chev '07-'10 LS3 6.0L, '08-'10 6.2L.....	\$119.95
<small>(A) Roller thrust bearing not included. (C) Raised Cam (B) Bronze thrust washer included. (D) Includes steel block plate.</small>	
Replacement Chains	
HRC94058.....94300, 94301, 94303, 94310 & 94312.....	\$27.95
HRC94066.....94305, 94315, 94335, & 94340.....	\$35.95



Billet Steel Timing Sets with IWIS Chain

The IWIS chain, designed and widely known for its strength and durability in the most extreme conditions. This precision made special heat-treated high strength steel chain is the choice of the most serious engine builders. These sets come matched with billet steel gears, 9-keyway crank sprocket, and Torrington thrust bearing.

HRC94700.....Chev SB, with IWIS Timing Chain.....	\$149.95
HRC94705.....Chev BB, with IWIS Timing Chain.....	\$162.95
HRC94712.....Ford 302, 351W '73-'02, with IWIS Chain.....	\$165.95



CLOYES Z-Racing Roller Billet Steel Timing Sets

The most durable and dependable chain available today. Offering 33% more overall strength than Cloyes standard true roller chain. Made from high strength steel with proprietary heat-treat processing. Includes billet steel gears, 9-keyway crank sprocket, and Torrington thrust bearing. The "Z-Series" is the choice for extreme engine builds that demand no compromise.

CLO9-3600TX9Z.....Chev SB.....	\$159.99
CLO9-3610TX9Z.....Chev BB (Mark IV).....	\$239.99



Crank Gear Install Tool

Makes pressing on gears straight easy. Use with #66514.

PFM67453.....Crank Gear Install Tool.....	\$21.99
---	---------





EXTREME BLACK™ SEVERE APPLICATION VALVES

Engineered for high rpm and high horsepower applications. Extreme Black™ feature a gloss black nitride and are perfect for high temperatures (they run cooler which improves valve life), nitrous, turbo and supercharger applications. For naturally aspirated motors these valves will give you a much greater cylinder flow for horsepower gains. They start as a one piece forged, high temperature, high nickel, stainless steel alloy. CNC finished to strict tolerances making these valves the choice for the most demanding race classes. The black nitride micro-hardness is higher than the stainless steel base material. No process can match it for surface hardness. Surface finish is smoother than with chromed stems, having less friction between stem and guide. The black nitride reduces power loss due to less valve-guide friction. Nitriding is not a coating, it is a process where it actually becomes part of the steel. Sold as each.

- High Nickel Stainless Alloy 1pc. Forgings
- Special Black Nitride Process (not a coating)
- Great for Naturally Aspirated Applications
- Great for Supercharged / Nitrous Applications
- Designed for High Horsepower Applications
- Runs Cooler, Improves Valve Life
- Fully CNC Machined Finished
- Surface Finish is Smoother than Chrome
- Higher Micro-Hardness than Stainless
- Undercut Stems for Increased Flow

Chevrolet SB	Type	Head Diameter	Stem Diameter	Installed Height	Overall Length	Tip Length	Underhead Angle / Radius	Margin	Seat Width	Top of Head	Weight (Grams)
19401N	Intake	1.940	11/32 (.3415)	Standard	4.911"	.250"	10° x .375"	.050	.100	6° Dish	111
20201N	Intake	2.020	11/32 (.3415)	Standard	4.911"	.250"	10° x .375"	.050	.100	6° Dish	116
20211N	Intake	2.020	11/32 (.3415)	+100"	5.011"	.250"	10° x .375"	.050	.100	6° Dish	124
20501N	Intake	2.055	11/32 (.3415)	Standard	4.911"	.250"	10° x .375"	.050	.100	6° Dish	131
20511N	Intake	2.055	11/32 (.3415)	+100"	5.011"	.250"	10° x .375"	.050	.100	6° Dish	119
20811N	Intake	2.080	11/32 (.3415)	+100"	5.011"	.250"	10° x .375"	.050	.100	6° Dish	120
15001N	Exhaust	1.500	11/32 (.3415)	Standard	4.911"	.250"	12° x .375"	.060	.100	7° Dish	89
16001N	Exhaust	1.600	11/32 (.3415)	Standard	4.911"	.250"	12° x .375"	.060	.100	7° Dish	94
16011N	Exhaust	1.600	11/32 (.3415)	+100"	5.011"	.250"	12° x .375"	.060	.100	7° Dish	95
16211N	Exhaust	1.625	11/32 (.3415)	+100"	5.011"	.250"	12° x .375"	.060	.100	7° Dish	105

Chevrolet LS (Bead Lock)

20208N	Intake	2.020	8mm (.3136)	Standard	4.900"	.206	12° x .375"	.050	.090	6° Dish	106
21608N	Intake	2.165	8mm (.3136)	Standard	4.900"	.206	12° x .375"	.050	.090	6° Dish	116
21618N	Intake	2.165	8mm (.3136)	+100"	5.000"	.206	12° x .375"	.050	.090	6° Dish	107
16008N	Exhaust	1.600	8mm (.3136)	Standard	4.920"	.206	25° x .4375"	.075	.090	18° Dish	91
16018N	Exhaust	1.600	8mm (.3136)	+100"	5.020"	.206	25° x .4375"	.075	.090	18° Dish	92

Chevrolet BB

22521N	Intake	2.250	11/32 (.3415)	+250"	5.494"	.250"	12° x .375"	.065	.100	7° Dish	149
23021N	Intake	2.300	11/32 (.3415)	+250"	5.494"	.250"	12° x .375"	.065	.100	7° Dish	155
23031N	Intake	2.300	11/32 (.3415)	+350"	5.594"	.250"	12° x .375"	.065	.100	7° Dish	160
18801N	Exhaust	1.880	11/32 (.3415)	Standard	5.422"	.250"	10° x .375"	.075	.100	6° Dish	121
18811N	Exhaust	1.880	11/32 (.3415)	+100"	5.522"	.250"	10° x .375"	.075	.100	6° Dish	125



LASH CAPS

Today's race engine technology and extreme cam profiles subject the tip of the valve stem to a tremendous amount of pounding. Designed to protect the valve stem under the most harsh conditions. Manufactured from premium quality chrome moly steel. Precision machined and ground perfectly flat to maintain accuracy. Provides a better wear surface for increased valve stem life. Lengthens valve .080" to correct rocker geometry. A must for high rpm engines. Sets of 16.

93200 5/16" x .250" Tip

93205 11/32" x .250" Tip

93210 3/8" x .250" Tip

POWER PRODUCTS

Stainless Steel High Performance Valve Sets

We continually beat up valve manufacturers on large quantities of valves. When they compete with each other to increase their sales, we pass the savings on to you. These are the same valves that other people are selling, but up to 65% less! These valves are manufactured of high grade 21-4N stainless steel material. Quality one-piece forgings. Valve stems are hard chromed and micro polished for an exceptional finish and to reduce wear. Fully machined combustion faces. Hardened tips to resist valve stem wear.



- One piece Forgings
- 21-4N Stainless steel
- Chrome stems
- Fully machined & polished
- Hardened tips
- Great quality

Special Set Pricing! from \$109.95 Set of 16!

Chev SB 11/32" Stem		Set of 16
PVT8430.....	(8) 1.940 Int. & (8) 1.500 Exh.....	\$109.95
PVT8435.....	(8) 1.940 Int. & (8) 1.600 Exh.....	\$109.95
PVT8445.....	(8) 2.020 Int. & (8) 1.500 Exh.....	\$109.95
PVT8440.....	(8) 2.020 Int. & (8) 1.600 Exh.....	\$109.95
PVT8441.....	(8) 2.020 +.100 & (8) 1.600 +.100.....	\$115.95

Chev BB 3/8" Stem		
PVT8455.....	(8) 2.065 Int. & (8) 1.720 Exh.....	\$119.95
PVT8456.....	(8) 2.190 Int. & (8) 1.720 Exh.....	\$119.95
PVT8450.....	(8) 2.190 Int. & (8) 1.880 Exh.....	\$119.95

Individual Stainless Steel High Performance Valves

High quality one-piece 21-4N stainless steel forgings. Hard chromed stems and micro polished for an exceptional finish to reduce wear. Fully machined combustion faces. Hardened tips to resist valve stem wear. Priced as each.

Chev SB (11/32" Stem)		Chev BB (3/8" Stem)			
PVT22-1500.....	1.500 Exhaust.....	\$8.59	PVT22-1720.....	1.720 Exhaust.....	\$9.39
PVT22-1600.....	1.600 Exhaust.....	\$8.59	PVT22-1880.....	1.880 Exhaust.....	\$9.39
PVT22-1601.....	1.600 Exhaust (+.100").....	\$8.99	PVT22-2060.....	2.065 Intake.....	\$9.39
PVT22-1940.....	1.940 Intake.....	\$8.59	PVT22-2190.....	2.190 Intake.....	\$9.39
PVT22-2020.....	2.020 Intake.....	\$8.59			
PVT22-2021.....	2.020 Intake (+.100").....	\$8.99			

MANLEY

Street Master Valves

Manufactured of XH-424 material for the exhaust and NK-841 for the intakes. They feature chrome stems and hard tips for reduced wear. Straight stems for added strength. Swirl polished. Fully machined faces. For better flow results, Street Flo valves feature undercut stems.

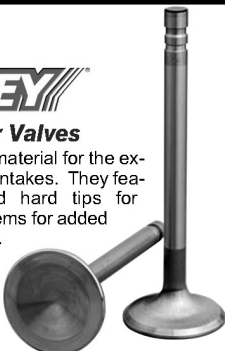

Chev SB		
MAN10777-1.....	1.500 Exhaust, 4.911" (std.).....	\$16.55
MAN10747-1.....	1.560 Exhaust, 4.911" (std.).....	\$16.55
MAN10749-1.....	1.600 Exhaust, 4.911" (std.).....	\$16.55
MAN10751-1.....	1.600 Exhaust, 5.011" (+.100").....	\$16.55
MAN10776-1.....	1.940 Intake, 4.911" (std.).....	\$16.55
MAN10750-1.....	2.020 Intake, 4.911" (std.).....	\$16.55
MAN10752-1.....	2.020 Intake, 5.011" (+.100").....	\$16.55
MAN10754-1.....	2.055 Intake, 4.911" (std.).....	\$16.55

Street Flo Valves With undercut stems.

Chev SB		
MAN10721-1.....	1.500 Exhaust, 4.911" (std.).....	\$16.55
MAN10765-1.....	1.600 Exhaust, 4.911" (std.).....	\$16.55
MAN10722-1.....	1.940 Intake, 4.911" (std.).....	\$16.55
MAN10766-1.....	2.020 Intake, 4.911" (std.).....	\$16.55

POWER PRODUCTS

Valve Spring Compressor

Change valve springs without removing the cylinder head. Works on any head with rocker arm studs and valve springs with any diameter.

PVT10-6848.....	Valve Spring Compressor.....	\$10.99
-----------------	------------------------------	----------------



HOWARD'S

cams

Lash Caps

Designed to protect the valve stem under the most harsh conditions. Manufactured from premium quality chrome moly steel. Precision machined and ground perfectly flat to maintain accuracy. Provides a better wear surface for increased valve stem life. Lengthens valve .080" to correct rocker geometry. A must for high rpm engines. Sold in sets of 16.

HRC93200.....	Lash Caps, 5/16" Stem.....	\$69.95
HRC93205.....	Lash Caps, 11/32" Stem.....	\$69.95
HRC93210.....	Lash Caps, 3/8" Stem.....	\$69.95

MANLEY

Race Flo Valves

Manufactured of XH-426 material for the exhaust and NK-842 for the intakes. They have chrome stems and hardened tips for reduced wear. Designed for bracket, drag and oval track racers operating below 8000 rpm. These valves are fully machined and swirl polished and feature Manley's "Pro Flow" underhead for increased flow.

- XH-426 exhaust material
- NK-842 intake material
- Chrome stems
- Hard tips
- Swirl polished
- Fully Machined
- Increased Flow with "Pro Flo" Underhead

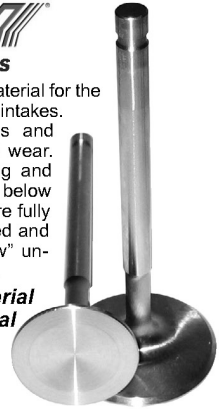

Chev SB Race Flo Special!

Your choice of 8 intakes or 8 exhaust. Only **\$170.62**

	Stem	Length	Tip	Part Number	Price ea.
1.500(exh)	11/32	4.911 (std.)	.250	MAN11521-1	\$22.45
1.600(exh)	11/32	4.911 (std.)	.250	MAN11565-1	\$22.45
1.600(exh)	11/32	5.065 (+.100)	.290	MAN11545-1	\$22.45
1.940(int)	11/32	4.911 (std.)	.250	MAN11522-1	\$22.45
2.020(int)	11/32	4.911 (std.)	.250	MAN11566-1	\$22.45
2.055(int)	11/32	4.911 (std.)	.250	MAN11568-1	\$22.45
2.055(int)	11/32	5.040 (+.100)	.290	MAN11546-1	\$22.45
2.080(int)	11/32	5.040 (+.100)	.290	MAN11560-1	\$22.45

Chev BB Race Flo Special!

Your choice of 8 intakes or 8 exhaust. Only **\$170.62**

1.725(exh)	3/8	5.350 (std.)	.220	MAN11517-1	\$22.45
1.880(exh)	3/8	5.350 (std.)	.220	MAN11527-1	\$22.45
2.065(int)	3/8	5.218 (std.)	.220	MAN11514-1	\$22.45
2.190(int)	3/8	5.218 (std.)	.220	MAN11528-1	\$22.45
2.250(int)	3/8	5.218 (std.)	.250	MAN11526-1	\$22.45

Ford SB (non-rail rockers) Race Flo Special!

Your choice of 8 intakes or 8 exhaust. Only **\$170.62**

1.600(exh)	11/32	4.911 (std.)	.250	MAN11531-1	\$22.45
1.940(int)	11/32	4.911 (std.)	.250	MAN11532-1	\$22.45
2.020(int)	11/32	4.911 (std.)	.250	MAN11566-1	\$22.45

All Manley Valves Available.



Valve Guide Flexhone

Blueprint your valve stem to guide clearance. Flexible, self-aligning, unbreakable. Lasts almost forever. American made.

BRM8532.....	Valve Guide Hone, 11/32".....	\$19.99
BRM8538.....	Valve Guide Hone, 3/8".....	\$16.99



Lash Caps

Because today's racing engines run at higher and higher rpm levels and the cam profiles are extremely harsh, the tip of the valve stem is subjected to a tremendous amount of pounding. Precision machined and ground perfectly flat to maintain accuracy of valvetrain adjustment. They fit the valve stems well and can be removed with relative ease because of a tiny hole to relieve the suction created when removing the lash cap. Sold in sets of 16.

CCA620-16.....	Lash Caps, 5/16" Stem.....	\$53.95
CCA621-16.....	Lash Caps, 11/32" Stem.....	\$50.95
CCA622-16.....	Lash Caps, 3/8" Stem.....	\$50.95

MANLEY

8mm Lash Caps

Constructed from 4140 heat-treated alloy steel. .080" thick. Sold in sets of 8.

MAN42125-8.....	Lash Caps, 8mm Stem.....	\$23.76
-----------------	--------------------------	----------------

Valves

Toll Free: 800-233-0199

Complete Head Improvement Kits

Everything you need to assemble your own high performance heads. **Note:** must shim valve springs to correct height.

○○○ **Unbeatable Deal** ○○○

Chev SB Hydraulic/Mechanical Flat Tappet Kits

With 10° Retainer & Valve Locks

For OE, Dart Iron Eagle S/S & 180, Engine Quest Vortec,
World S/R & S/R Torquer Heads

Each Complete Kit Includes:

- 16 Stainless Steel Valves, One piece, Chrome Stem, Hardened Tip
- 16 Performance Hydraulic/Mechanical Flat tappet Valve Springs
110 @ 1.800", 340 @ 1.150", 1.160" Coil Bind, .570" Max Lift
- 16 Steel 10° Valve Spring Retainers
- 32 Forged Steel 10° Valve Locks
- 16 VTO Ultimate Duty Valve Seals



CMP851295	Kit, w/1.94"-1.50" Valves, Hyd./Mech. FT to .570" Lift.....	\$159.95
CMP851296	Kit, w/1.94"-1.60" Valves, Hyd./Mech. FT to .570" Lift.....	\$159.95
CMP851225	Kit, w/2.02"-1.50" Valves, Hyd./Mech. FT to .570" Lift.....	\$159.95
CMP851226	Kit, w/2.02"-1.60" Valves, Hyd./Mech. FT to .570" Lift.....	\$159.95

Kits Available with +.100" Valves, Call for details

○○○ **Exclusive** ○○○

Chev SB 8mm Lightweight Valvetrain Conversion

Designed for better valve control and increased valvetrain stability. These lightweight conversions start with valves with smaller 8mm stems. They feature inverted conical valve springs and small 1.055" diameter retainers for even more weight savings. Because of this reduction in weight, you can use less spring pressure to handle more rpm and more aggressive cam profiles. Valves and valve locks are bead lock design for better clamping force. Perfect for occasional use at the strip, but durable for the street. Great for hydraulic/mechanical flat tappet or hydraulic roller cam applications. **Note:** Conversion requires use of either 8mm valve guide liners or 8mm valve guides (listed below).

Each Complete Kit Includes:

- 16 Stainless Steel Valves with 8mm Valve Stems
One piece, Chrome Stem, Hardened Tip
- 16 Howards Cams™ Beehive Valve Springs
108 @ 1.800", 345 @ 1.225", 1.150" Coil Bind, .600" Max Lift
- 16 Small Diameter Steel Valve Spring Retainers
- 32 Bead Lock Valve Locks



CMP851026	8mm Conversion, with 2.020"/1.600", Std. Length.....	\$239.95
CMP851027	8mm Conversion, with 2.020"/1.600", +.100".....	\$239.95
CMP851056	8mm Conversion, with 2.055"/1.600", +.100".....	\$249.95

VT08027	8mm Bronze Valve Guide Liners (requires honing), Each	\$1.59
VT05800	8mm Valve Seal, 8mm x .500 (.600" O.D.), Set of 16.....	\$22.95
VT05810	8mm Valve Seal, 8mm x .531 (.675" O.D.), Set of 16.....	\$22.95

GM Gen III (LS1/2/3/6/L92) For OE, AFR Mongoose, Dart Pro1

Each kit includes high grade performance parts with stainless steel valves. Kits designed for hydraulic roller applications.

Hydraulic Roller to .620" lift Applications
120@1.800", 330@1.200, Coil Bind: 1.125"

Kit includes: #98113 hi-performance inverted conical springs, #3211 steel retainers, #4212 bead-loc valve locks, and 8mm stainless steel, swirl polished, one-piece race valves with chrome stems and hardened tips.

CMP854125	Kit, w/2.020"-1.57" Valves.....	\$279.95
CMP854126	Kit, w/2.020"-1.60" Valves.....	\$299.95



Hydraulic Roller Applications to .650" lift
135@1.800", 375@1.150, Coil Bind: 1.100"

Kit includes: #98116 hi-performance 1.290" dual springs, chrome moly steel retainers, 8mm Heat-treated valve locks, stainless steel, swirl polished one-piece race valves with chrome stems and hardened tips. These kits also include small O.D. valve seals.

CMP854225	Kit, w/2.020"-1.57" Valves.....	\$439.95
CMP854226	Kit, w/2.020"-1.60" Valves.....	\$449.95
CMP854286	Kit, w/2.080"-1.60" Valves.....	\$449.95
CMP854216	Kit, w/2.150"-1.60" Valves.....	\$459.95





Carbide Cutters

American made. Can be resharpened up to 40 times at fraction of new cost. 1/4" shank. Production shop quality. Available for use with Aluminum or Cast Iron.

for Cast Iron	
DC3032	.375 x 2.5" oval for cast iron, each\$19.99
DC3034	.375 x 4.5" oval for cast iron, each\$31.99
DC3052	.500 x 3" oval for cast iron, each\$25.99
DC3054	.500 x 4-7/8" oval for cast iron, each\$39.99
RC3032	.375 x 2.5" tree for cast iron, each\$24.99
RC3034	.375 x 4.75" tree for cast iron, each\$23.99
RC3042	.437 x 3" tree for cast iron, each\$34.99
RC3044	.437 x 5" tree for cast iron, each\$39.99
Cast Iron Carbide Cutter Set	
3 of the most popular cutters in a money saving set.	
DRC303 pc. Set (DC3034, DC3054 & RC3042)\$95.99
for Aluminum	
DHOG52	.500 x 3" oval for aluminum, each\$29.99
DHOG54	.500 x 5" oval for aluminum, each\$37.99
RHOG42	.437 x 3" tree for aluminum, each\$32.99
RHOG44	.437 x 5" tree for aluminum, each\$35.99
RHOG52	.500 x 3" tree for aluminum, each\$34.99
RHOG54	.500 x 5" tree for aluminum, each\$38.99
FHOG54	.500 x 4" flame for aluminum, each\$38.99
FHOG64	.625 x 4" flame for aluminum, each\$87.99
Aluminum Carbide Cutter Set	
3 of the most popular cutters in a money saving set.	
DRHOG503 pc. Set (DHOG54, RHOG44 & RHOG52)\$99.99



STANDARD ABRASIVES Precision Cartridge Roll Kits

The next step beyond cartridge rolls when it comes to precision porting and polishing jobs. Unique construction provides a longer lasting, vibration-free, high-end abrasive tool like no other in the automotive aftermarket. They are used by some of the top head porting shops and schools throughout the world. Includes (7) Precision Cartridge rolls of various sizes and grits.

- Smooth, vibration-free operation provides smoother final finish
- Abrasive core allows the entire roll to be used, nothing is wasted
- Outlasts a normal cartridge roll up to 7 times
- Can be used on aluminum and cast iron heads

PVT16-6044Precision Cartridge Roll Kit, 7 pc. Set.....\$32.99
STA726020R4, 1/4" x 1-1/4" x 1/8", 80 Grit, Straight, each\$2.29
STA726029R4, 1/4" x 1-1/4" x 1/8", 100 Grit, Straight, each\$1.99
STA726019R4, 1/4" x 1-1/4" x 1/8", 320 Grit, Straight, each\$2.29
STA726003R6, 3/8" x 1-3/4" x 1/4", 80 Grit, Straight, each\$2.99
STA726002R6, 3/8" x 1-3/4" x 1/4", 100 Grit, Straight, each\$3.29
STA726006R8, 1/2" x 1-3/4" x 1/4", 80 Grit, Straight, each\$3.59
STA726001R8, 1/2" x 1-3/4" x 1/4", 100 Grit, Straight, each\$3.59
STA726016C1, 1/2" x 2-1/2" x 1/4", 80 Grit, Straight, each\$6.29
STA726037C2, 5/8" x 2-1/2" x 1/4", 180 Grit, Straight, each\$5.69
STA726007C3, 13/16" x 2-1/2" x 1/4", 80 Grit, Straight, each\$9.49
STA726000C4, 1" x 2-1/2" x 1/4", 60 Grit, Straight, each\$8.29

* Included in Precision Cartridge Roll Kit PVT16-6044



92pc Cartridge Roll Kits

A great value! Save time and money with this generous assortment of the most popular types and grits of straight cartridge rolls, in coarse, medium and fine grades. Essential tools for engine porting, including intake manifold, heads and exhaust manifold. Kit includes 1/4", 3/8" and 1/2" cartridge rolls and mandrels. A total of 92 pieces. Kits include:

- (15) 1/4" x 1" x 1/8" 80 grit • (10) 1/4" x 1-1/2" x 1/8" 80 grit
- (15) 1/4" x 1" x 1/8" 120 grit • (10) 1/4" x 1-1/2" x 1/8" 120 grit
- (10) 3/8" x 1" x 1/8" 80 grit • (6) 3/8" x 1-1/2" x 1/8" 80 grit
- (6) 3/8" x 1-1/2" x 1/8" 120 grit • (6) 1/2" x 1" x 1/8" 80 grit
- (4) 1/2" x 1-1/2" x 1/8" 60 grit • (4) 1/2" x 1-1/2" x 1/8" 80 grit
- (4) 1/2" x 1-1/2" x 1/8" 120 grit • 2 Mandrels

PVT16-0038.....Cartridge Roll Kit.....\$39.99

Replacement Cartridge Rolls

Aluminum Oxide, Straight	Box of 100	Each
STA7115991/4" x 1" x 1/8", 80 grit.....	\$31.20 39¢
STA7076201/4" x 1" x 1/8", 120 grit.....	\$39.20 49¢
STA7044061/4" x 1-1/2" x 1/8", 60 grit.....	\$39.20 49¢
STA7056861/4" x 1-1/2" x 1/8", 80 grit.....	\$39.20 49¢
STA7099071/4" x 1-1/2" x 1/8", 120 grit.....	\$39.20 49¢
STA7051963/8" x 1" x 1/8", 60 grit.....	\$39.20 49¢
STA7064543/8" x 1" x 1/8", 80 grit.....	\$39.20 49¢
STA7025133/8" x 1-1/2" x 1/8", 40 grit.....	\$47.20 59¢
STA7037323/8" x 1-1/2" x 1/8", 60 grit.....	\$47.20 59¢
STA7050363/8" x 1-1/2" x 1/8", 80 grit.....	\$47.20 59¢
STA7060443/8" x 1-1/2" x 1/8", 100 grit.....	\$47.20 59¢
STA7073363/8" x 1-1/2" x 1/8", 120 grit.....	\$39.20 49¢
STA7132263/8" x 2" x 1/8", 60 grit.....	\$55.20 69¢
STA7076171/2" x 1" x 1/8", 80 grit.....	\$39.20 49¢
STA7079471/2" x 1-1/2" x 1/8", 40 grit.....	\$55.20 69¢
STA7091871/2" x 1-1/2" x 1/8", 60 grit.....	\$55.20 69¢
STA7104791/2" x 1-1/2" x 1/8", 80 grit.....	\$55.20 69¢
STA7098131/2" x 1-1/2" x 1/8", 120 grit.....	\$55.20 69¢
STA7006241/2" x 1-1/2" x 1/8", 180 grit.....	\$55.20 69¢

Aluminum Oxide, Straight	Box of 50	Each
STA7073081/2" x 2" x 1/8", 60 grit.....	\$35.60 89¢
STA7085641/2" x 2" x 1/8", 80 grit.....	\$35.60 89¢
STA7136563/4" x 1" x 1/8", 80 grit.....	\$39.60 99¢
STA7149793/4" x 1-1/2" x 1/8", 40 grit.....	\$55.60 \$1.39
STA7134443/4" x 1-1/2" x 1/8", 80 grit.....	\$47.60 \$1.19

Aluminum Oxide, Half Tapered	Box of 50	Each
STA7074455/8" x 1-1/2" x 1/8", 100 grit.....	\$51.60 \$1.29

Aluminum Oxide, Full Tapered	Box of 100	Each
STA7042143/8" x 1-1/2" x 1/8", 60 grit.....	\$79.20 99¢
STA7055093/8" x 1-1/2" x 1/8", 80 grit.....	\$71.20 89¢
STA7069683/8" x 1-1/2" x 1/8", 120 grit.....	\$71.20 89¢
STA7096531/2" x 1-1/2" x 1/8", 60 grit.....	\$63.20 79¢
STA7109281/2" x 1-1/2" x 1/8", 80 grit.....	\$63.20 79¢
STA7009391/2" x 1-1/2" x 1/8", 120 grit.....	\$79.20 99¢

Aluminum Oxide, Full Tapered	Box of 50	Each
STA7006671/2" x 2" x 1/8", 60 grit.....	\$27.60 69¢
STA7019741/2" x 2" x 1/8", 80 grit.....	\$39.60 99¢
STA7105803/4" x 1-1/2" x 1/8", 80 grit.....	\$39.60 99¢

* Included in Cartridge Roll Kit PVT16-0038

STANDARD ABRASIVES Cartridge Roll Mandrels

Mandrel enables access to tight spaces with a cartridge roll. Comes in various lengths to fit different cartridge rolls. Made of plated steel for enhanced durability

STA700717CM-8, 1/8" x 3/4" x 2-1/2", 1/4" Shank, each\$4.99
STA710190CM-9, 1/8" x 1" x 2-3/4", 1/4" Shank, each\$4.59
STA717919CM-XL, 1/8" x 1" x 4", 1/4" Shank, each\$6.39
STA716295CM-XL, 1/8" x 1" x 5", 1/4" Shank, each\$8.59
STA708897CM-6, 1/8" x 1-1/2" x 3-1/2", 1/8" Shank, each\$4.79
STA712230CM-11, 1/8" x 2" x 4", 1/4" Shank, each\$3.99

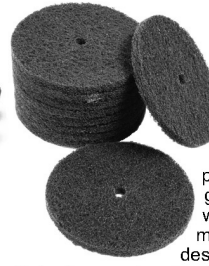

STANDARD ABRASIVES Buff & Blend Bench Grinder Discs

Quickly remove carbon from pistons and valve stems. Great for light deburring. Replaces wire wheel on 6" bench grinders. One disc is flexible when run alone. Stack as many discs on at a time for the desired finish and removal rate.

STA8607086" x 1/2", Very Fine, pack of 10\$35.99
STA8107106" x 1/2", Medium, pack of 10\$69.99

STANDARD ABRASIVES Deburring Wheels for Bench Grinders

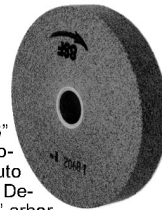

Replaces grinding wheels on 6" bench grinders. Cleans rust, corrosion, and light scratches from auto parts. Deburr and polish pistons. Deburr valve springs and valves. 1" arbor hole requires proper size reducer bushing.

STA8541936" x 1", Hard Density, Fine Grade\$75.99
-----------	---

STANDARD ABRASIVES Flap Wheels

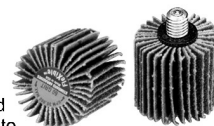

Flap Wheels are composed of abrasive strips, bonded to a hub. Very useful for blending and polishing.

with 1/4" Shank	Box of 10	Each
STA6114051" x 1", 60 Grit.....	\$48.51 \$5.39
STA6114081" x 1", 120 Grit.....	\$62.01 \$6.89

with 1/4"-20 Thread (requires mandrel)	Box of 10	Each
STA6214051" x 1", 1/4"-20, 60 Grit.....	\$71.91 \$7.99
STA6214061" x 1", 1/4"-20, 80 Grit.....	\$66.51 \$7.39
STA6214081" x 1", 1/4"-20, 120 Grit.....	\$71.91 \$7.99
STA269201Mandrel, 1/4" x 1/4" x 4".....	\$11.99

BRM Lifter Bore Flexhone

Make sure your lifters will rotate in their bores. Flexible self-aligning, unbreakable Silicon Carbide hone. Lasts almost forever. One size fits all.

Cleans fast - be careful not to enlarge bores.

BRM8534Flexhone, Lifter Bore\$19.99
---------	---

BRM Valve Guide Flexhone

Blueprint your valve stem to guide clearance. Flexible, self-aligning, unbreakable. Lasts almost forever. American made.

BRM8532Valve Guide Hone, 11/32".....\$17.99
BRM8538Valve Guide Hone, 3/8".....\$16.99



Cylinder Block Flex Hones

Heavy duty, fits bores from 4" to 4 1/2". A flexible, self-centering, self-aligning, self-compensating, for wear, unbreakable honing device with long life and consistent finish. Globules of silicon carbide laminated to the ends of hi-density nylon creates a flexible hone which requires no set-up, does not get out of shape and most important, imparts a consistent perfect cross hatch for oil retention and instant ring sealing.

BRM8525Cylinder Hone, 4"-4-1/2", 120 Grit.....\$98.95
BRMGDB41232Cylinder Hone, 4"-4-1/2", 320 Grit.....\$145.95





STANDARD™ ABRASIVES **Block Prep Kits**

Prepping a block properly will ensure longer engine life and better performance. These kits are designed to restore the original finish to the block and removes casting imperfections. Used by many of the top professional engine builders. These 50 piece kits include (6) quick change 2" sanding disc, (8) 2" quick change surface conditioning disc, (4) 1" x 1" flap wheels, (3) cross buffs, (22) cartridge rolls, (1) 2" holder pad for quick change disc, (1) 1/4" mandrel for holder pad, (1) 1/4"-20 x 4" mandrel for cross buffs or flap wheels, (1) 1/4"-20 x 2-3/4" mandrel for cartridge rolls and (3) set screws for combination mandrels.

PVT16-0003.....Block Prep Kit.....\$82.99



STANDARD™ ABRASIVES **Cross Buff® Kits**

Unique design! Made exclusively to help auto mechanics hone and polish the I.D. of lifter bores, valve bodies, and brake cylinders. Clean and polish venturis of carburetors and exhaust ports of cylinder heads. Includes (2) 1" Medium Cross Buffs, (2) 1" Very Fine Cross Buffs, (2) 1-1/2" Medium Cross Buffs (2) 1-1/2" Very Fine Cross Buffs, and 4" x 1/4"-20 mandrel.

STA260013.....Cross Buff Kit.....	\$62.99
Cross Buffs	Box of 50 Each
STA727334.....1" Course HS.....	\$170.55 \$3.79
STA725007.....1" Medium HP.....	\$170.55 \$3.79
STA725008.....1" Very Fine HP.....	\$166.05 \$3.69
STA725005.....1-1/2" Medium HP.....	\$323.55 \$7.19
STA725006.....1-1/2" Very Fine HP.....	\$323.55 \$7.19
Combination Mandrels (Cross Buff/Flap Wheel)	
STA269201.....1/4" x 1/4" x 4", each.....	\$11.99



STANDARD™ ABRASIVES **Gasket Removal Kits**

There's an easier way to remove gaskets and silicone. These Quick Change Surface Conditioning Discs provide time-saving convenience. The right tools for removal of gaskets from blocks, heads, thermostat housing, and water pumps. Kits include 4 Quick Change (TS) Surface Conditioning Discs (2, 2" medium & 2, 2" very fine), 2" holder pad and 1/4" mandrel.

PVT16-0010.....Gasket Removal Kit.....\$24.99

Replacement Quick Change Discs

Surface Conditioning Discs	Box of 50	Each
STA840333.....2" Very Fine, each.....	\$71.55	\$1.59
STA840332.....2" Medium, each.....	\$71.55	\$1.59
Aluminum Oxide Sanding Discs	Box of 100	Each
STA522407.....2", 100 Grit, each.....	\$103.20	\$1.29
STA522409.....2", 150 Grit, each.....	\$135.20	\$1.69
Holder Pad & Mandrel Kits		
STA541057.....2", Pad w/TA4 (1/4") Mandrel, each.....	\$21.99	



STANDARD™ ABRASIVES

Mini Porting Kit

Designed for minor cleanups and repairs. Includes (1) precision cartridge roll, (10) cartridge rolls and (1) 1/4" x 4" mandrel for cartridge rolls.

PVT16-8090.....Mini Porting Kit, 12 pcs.....\$11.99



STANDARD™ ABRASIVES **Basic Porting Kits**

Great 25 piece kit for touching up a set of heads that have already been ported and polished. When freshening up a set with a valve job and new springs, this kit will make the job complete. Includes (1) 1" x 1" flap wheel, (3) 1-1/2" cross buffs, (18) cartridge rolls, (1) 1/4" x 4" mandrel for cross buffs or flap wheels, (1) 1/4" x 5" mandrel for cartridge rolls and (1) set screw for combination mandrel.

PVT16-0012.....Basic Porting Kit, 25 pcs.....\$54.95



STANDARD™ ABRASIVES **Brite Rite E-Z Hand Pads**

Designed for hand applications such as deburring, polishing, cleaning, finishing, and surface preparation on metal composite or plastic surfaces. Non-rusting, will not contaminate work piece. Flexible, conforms to work piece. Uniform distribution of grain for a consistent finish. Washable, reusable.

STA827500.....Ultra Fine, Gray, 6" x 9", pack of 10.....	\$11.99
STA827505.....Medium, Maroon, 6" x 9", pack of 10.....	\$13.99
STA827510.....Coarse, Tan, 6" x 9", pack of 10.....	\$29.99



VALCO CINCINNATI PIONEER Automotive Industries **Gasket Remover**

The Peeler™ is amazingly effective at removing silicone gasket material. It also works well when removing paper or fiber gasket residue. It is much easier and faster than common knives or scrapers. The Peeler's unique, self-leveling conical blade does not dig or gouge into surfaces. Free rotation of the blade maintains a good, sharp cutting edge without nicks or flat spots. The Peeler can be used in any of the following motions: forward, backward, sideways, circular, and upside-down.

VAL71688.....The "Peeler™" Gasket Remover.....\$29.99



VALCO CINCINNATI **"Powered Peeler" Gasket Remover**

Designed for powered screw drivers and air-ratchets (max. 500 rpm). It fits 9/16" sockets. Like The Peeler™, it is amazingly effective at removing silicone gasket material. It also works well when removing paper or fiber gasket residue. It is much easier and faster than common knives or scrapers. The Peeler's unique, self-leveling conical blade does not dig or gouge into surfaces.

VAL71371.....The "Powered Peeler™" Gasket Remover.....\$29.99



Standard Porting Kits

A very complete porting kit, though not quite as trick as the Deluxe Porting Kit. Does not include cross buffs, but does have a large variety of cartridge rolls for a complete porting job. Includes (2) 1" x 1" flap wheels, (2) rotary stones (42) cartridge rolls, (1) 1/4" x 2-3/4" mandrel, and (1) 1/4" x 4" mandrel for cartridge rolls.

PVT16-0011.....Standard Porting Kit, 48 pcs.....\$54.95



STANDARD™ ABRASIVES **Deluxe Cylinder Head Port and Polishing Kits**

Designed for the do-it-yourself porter. Port, polish, and remove flashing on engine parts with an electric drill or die grinder. Ideal for cast iron or aluminum heads and intake manifolds. The Deluxe Port and Polishing kit includes, 51 pieces in all, (2) flapwheels, (42) cartridge rolls, (3) mandrels, and (4) cross buffs.

PVT16-0001.....Deluxe Port & Polishing Kit, 55 pcs.....\$89.95



STANDARD™ ABRASIVES **Port and Polishing Master Kits**

The most complete and comprehensive cylinder porting kit available today. Designed for the advanced do-it-yourself porter. Port, polish, and remove flashing on engine parts with an electric drill or die grinder. Ideal for cast iron or aluminum heads as well as intake manifolds. Includes 175 pieces in all.

Cartridge Rolls:

(5) 1/4" x 1-1/2" x 1/8" 60 Grit	(5) 1/4" x 1-1/2" x 1/8" 80 Grit
(5) 1/4" x 1-1/2" x 1/8" 120 Grit	(5) 3/8" x 1" x 1/8" 80 Grit
(10) 3/8" x 1-1/2" x 1/8" 80 Grit	(10) 3/8" x 1-1/2" x 1/8" 60 Grit
(10) 3/8" x 1-1/2" x 1/8" 80 Grit	(5) 3/8" x 1-1/2" x 1/8" 80 Grit *
(5) 3/8" x 1-1/2" x 1/8" 120 Grit	(5) 3/8" x 2" x 1/8" 60 Grit
(5) 1/2" x 1" x 1/8" 80 Grit	(10) 1/2" x 1-1/2" x 1/8" 40 Grit
(10) 1/2" x 1-1/2" x 1/8" 60 Grit	(5) 1/2" x 1-1/2" x 1/8" 60 Grit *
(10) 1/2" x 1-1/2" x 1/8" 80 Grit	(5) 1/2" x 1-1/2" x 1/8" 120 Grit
(5) 1/2" x 2" x 1/8" 60 Grit	(10) 1/2" x 2" x 1/8" 80 Grit
(5) 5/8" x 1-1/2" x 1/8" 100 Grit *	(5) 3/4" x 1" x 1/8" 80 Grit
(5) 3/4" x 1-1/2" x 1/8" 40 Grit	(5) 3/4" x 1-1/2" x 1/8" 80 Grit

Precision Cartridge Rolls:

(2) R4, 1/4" x 1-1/4" x 1/8" 320 Grit	(1) R6, 3/8" x 1-3/4" x 1/4" 100 Grit
(1) R8, 1/2" x 1-3/4" x 1/4", 80 Grit	(1) R8, 1/2" x 1-3/4" x 1/4", 100 Grit
(1) C1, 1/2" x 2-1/2" x 1/4", 80 Grit	(1) C2, 5/8" x 2-1/2" x 1/4", 180 Grit
(1) C3, 13/16" x 2-1/2" x 1/4", 80 Grit	(1) C4, 1" x 2-1/2" x 1/4", 60 Grit

Cross Buffs Included:

(2) 1" Course HS	(4) 1-1/2" Medium HP	(2) 1-1/2" Very Fine HP
------------------	----------------------	-------------------------

Flap Wheels Included:

(2) 1" x 1, 1/4"-20, 120 Grit	(2) 1" x 1", 1/4"-20, 80 Grit
-------------------------------	-------------------------------

Mandrels Included:

(1) CM-9 1/8" x 1" x 2-3/4"	(1) CM-XL 1/8" x 1" x 5"
(1) CM-11, 1/8" x 2" x 4", 1/4"	(1) 1/4" x 1/4" x 4" (Cross Buff/Flap)

PVT16-0002.....Master Port & Polishing Kit, 175 pcs.....\$189.95



280 W. 35th Avenue
Oshkosh, Wisconsin
54902-7173

PRSR STD
US POSTAGE
PAID
UMS

SUPER DEALS - All Sales Final!

Toll-Free Ordering:
1.800.233.0199

CALL FOR OUR FULL-LINE
276 PAGE CATALOG!

All sales final | Not liable for misprints

www.competitionproducts.com